

It's
hand
made
light

news
2019

el**torrent**

Index

14	Cuca
20	Cloche
26	Quadra
34	Twice
40	Materials

Outdoor

Floor lamps *Lámparas de pie*

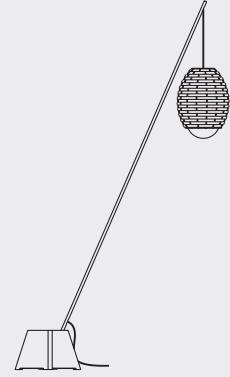

Cuca
14

Pendant lamps *Lámparas Colgantes*

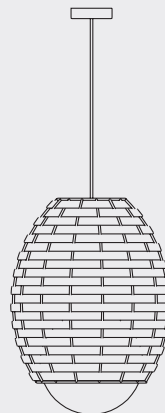

Cuca
14



Cloche
20

Table lamps *Lámparas de sobremesa*

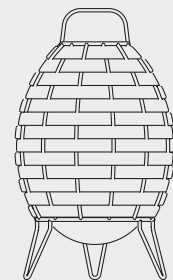

Cuca
14

Indoor

Pendant lamps
*Lámparas
colgantes*

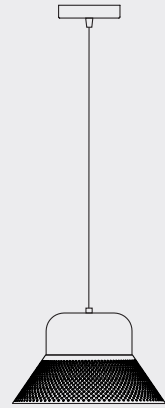

Cloche
20

Wall lights
Apliques



Quadra
26

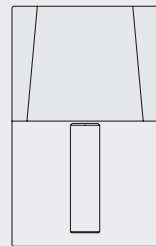

Twice
34

Table lamps
*Lámparas
de sobremesa*

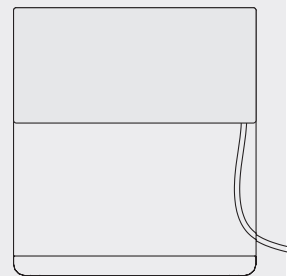

Quadra
26

It's
hand
made
light

Designers



Joan Genebat

“The challenge and main objective is to successfully convey the desired sensations.

Light has contrasting characters and personalities; we discover them step by step...”

“Conseguir transmitir sensaciones es el reto y el objetivo más grande.

La luz tiene caracteres y personalidades muy diferentes, se van conociendo poco a poco...”



Crous Calogero

“We want our objects, materials and details of each product to convey a desire to be touched and observed close up. Functionality is a basic requirement that we consider essential, and on which we try to suggest a narrative, consisting of memories and sensations, generating an intangible bond between object and person.”

“Queremos que nuestros objetos, la materia y detalle de cada producto, transmitan el deseo de ser tocados y observados de cerca. La funcionalidad es un requisito de base que damos por sentado y sobre el cual tratamos de sugerir una historia, hecha de memorias y sensaciones, que genere el vínculo impalpable entre objeto y persona.”



Roger Vancells

“The working method helps reveal the beauty of everyday objects, making them simple, functional and clear, by using attractive, sincere solutions arising from our constant search for innovation”

“El método de trabajo incide en conseguir revelar la belleza de las cosas cotidianas haciéndolas sencillas, funcionales y claras, utilizando para ello soluciones atractivas, sinceras y fruto de una mirada constante hacia la innovación.”

news
2019



Cuca

by Crous Calogero,
(Francesc Crous and Alessandro Calogero)



This new outdoor collection, consisting of standing, floor, table and hanging lamps, is characterised by its organic shapes and warmth, defining features of our models.

The shades in the form of elliptical globes are braided, reminiscent of malacca, with a new neoprene material coated with a fabric suitable for outdoors, while the interior is a large opal triplex glass sphere.

They provide a point of warm light for any outdoor or indoor space.

Esta nueva colección outdoor, compuesta de pie, suelo, sobremesa y suspensión, se caracteriza por sus formas orgánicas y su calidez, tan propias de nuestros modelos.

Sus pantallas con forma de globo elíptico se presentan trenzadas, recordando al ratán, con un nuevo material de neopreno recubierto de textil apto para exterior, y en su interior una gran esfera de vidrio triplex opal.

Aportan un punto de luz cálida en cualquier espacio exterior y también interior.

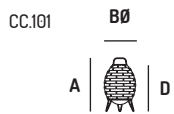

Lights with metal structure treated for outdoors (nanophoresis), painted in grey RAL7032 and braided with UV-treated flecked textile material.

Luminarias de estructura metálica con tratamiento para exterior (nanoforesis), pintada en gris RAL7032 y trenzado con material textil jaspeado tratamiento UV.

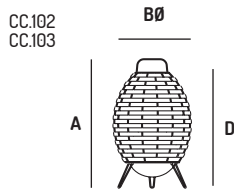

Standing model with stainless steel arm (AISI-304) and grey polyester (RAL7032) finish. White polymer concrete base.

Modelo de pie con brazo de acero inoxidable (AISI-304) acabado en pintura gris (RAL7032) de poliéster. Base en hormigón polímero blanco.

Pendant lamp with fleuron and black neoprene cable.

Colgante con florón y cable neopreno negro.

Bombilla LED incluida.

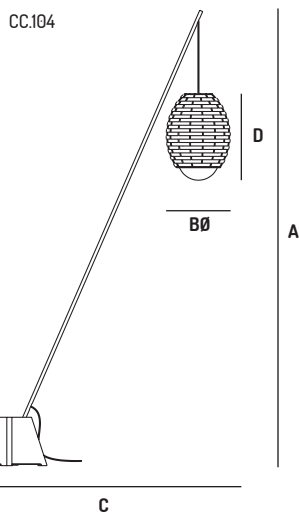

LED bulb included.

Modelo de sobremesa con sistema de iluminación LED. Módulo LED regulable incluido.

Table model with LED lighting system. Dimmable LED module included.

ref	TYPE	A	BØ	C	D	DIF	BULB A+
CC.101	TABLE LAMP	32 cm	20 cm	-	28 cm	•	LED 8W 230V 2700K 800lm Dimmable TRIAC*
CC.102	FLOOR LAMP, STANDING	78 cm	50 cm	-	70 cm	•	1xE27 LED 14W 2700K (included)
CC.103	FLOOR LAMP, STANDING	110 cm	68 cm	-	100 cm	•	1xE27 LED 14W 2700K (included)
CC.104	FLOOR LAMP, HANGING	270 cm	40 cm	180 cm	50 cm	•	1xE27 LED 14W 2700K (included)
CC.105	PENDANT LAMP	170 cm	40 cm	-	50 cm	•	1xE27 LED 14W 2700K (included)

CE IP64 CC. 101, CC.102, CC.103
 CE IP64 CC. 104

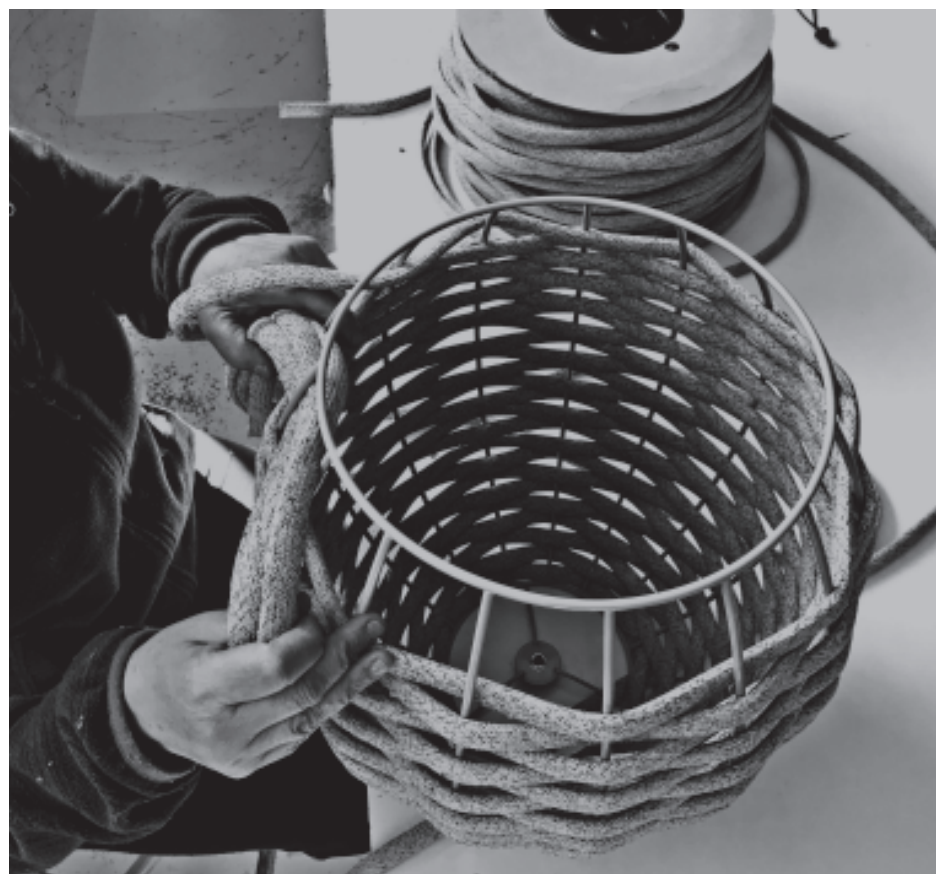
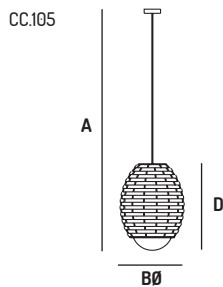









Cloche

by Joan Genebat



Cloche evokes memories of the Roaring

Twenties. It is an indoor/outdoor hanging lamp, combining elegance and naturalness.

Made out of locally sourced cork, the LED module is covered with a perforated metal visor in anthracite grey or off white. It also comes with an indoor LED bulb. Decorative and close to nature, for highlighting family and leisure areas.

Cloche nos evoca el recuerdo de esos locos

años 20 del siglo pasado. Es una suspensión indoor/outdoor que combina elegancia y naturalidad.

Fabricada en corcho autóctono de nuestra zona, cubre su módulo LED con una visera de metal perforado en gris antracita o blanco roto. También se ofrece con bombilla LED para interior. Decorativa y cercana a la naturaleza, realza las zonas de encuentro familiares o de ocio





Hanging lamp made from treated cork and perforated metal sheet with antioxidant treatment (nanophoresis) and polyester paint, available in off white (RAL9001) and anthracite grey (RAL7024). Available with black fabric cable and bulb in the indoor version and neoprene cable and 10 W LED module in the outdoor version.

Lámpara de suspensión fabricada en corcho tratado y chapa metálica perforada con tratamiento antioxidante (nanoforesis) y pintura de poliéster, disponible en blanco roto (RAL9001) y gris antracita (RAL7024). Disponible con cable textil negro y bombilla en la versión indoor o cable neopreno y módulo LED 10 W en la versión outdoor.

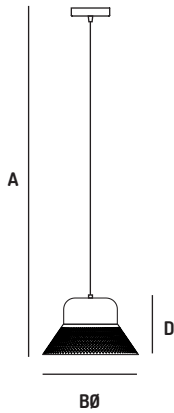

ref	TYPE	A	BØ	C	D	DIF	BULB A+
○ CH.001.00W	PENDANT LAMP	138 cm	30cm	-	18cm		⦿ 1xE27 LED 12W
● CH.001.00G	PENDANT LAMP	138 cm	30cm	-	18cm		⦿ 1xE27 LED 12W
○ CH.101.14W	PENDANT LAMP	138 cm	30cm	-	18cm	•	⦿ LED 10W 230V 2700K 850lm Dimmable TRIAC
● CH.101.14G	PENDANT LAMP	138 cm	30cm	-	18cm	•	⦿ LED 10W 230V 2700K 850lm Dimmable TRIAC

CE IP20 CH.001.00W, CH.001.00G

CE IP54 CH.101.00W, CH.101.00G







Quadra

by Roger Vancells



Quadra is a collection in a minimalist, rational style. Its design seeks a harmonious combination of materials and their relation to light as the main leitmotiv. Design, functionality and practicality are blended in this line of two types of lamp: table and wall.

Designed for public and transit areas, it is made with a metal structure, beech wood and a washable textile shade. The purity of its lines makes it the ideal complement for all decorative styles.

Quadra es una colección de confección minimalista y líneas racionales. Su diseño propone la convivencia entre diversos materiales y su relación con la luz como principal leitmotiv. Diseño, funcionalidad y la practicidad se funden en esta línea de dos luminarias: sobremesa y aplique.

Ideada para espacios públicos y de tránsito, está hecha de estructura metálica, madera de haya y pantalla textil lavable. Sus líneas puras la convierten en el complemento ideal de cualquier estilo decorativo.





Quadra 27



LA FESTA a les terres de Girona

L'EIXAMPLE DE BARCELONA

VIGILIOS
SÁNCHEZ PIÑOL
ALBERT SÁNCHEZ PIÑOL
VIGILIOS
BARCELONA
NOVELA



TEMAR
198

Dräger
in ricordo

100
AÑOS de DEPORTE
del esfuerzo
individual
al espectáculo
de masas

19

Table lamp with metal structure and shade in technical fabric, Available in black or white opaque screen. Beech wood with a matt finish. LED lighting system.

Sobremesa con estructura metálica y pantalla en tejido técnico screen, disponible en screen opaco en blanco o negro. Madera de haya acabado mate. Sistema de iluminación LED.

Wall lamp with metal structure and shade in technical fabric, available in black or white. Beech wood with a matt finish. LED lighting system.

Aplique con estructura metálica y pantalla en tejido técnico screen, disponible en blanco o negro. Madera de haya acabado mate. Sistema de iluminación LED.

Also available in linen and cotton Group A material.

También disponible en material lino y algodón Grupo A

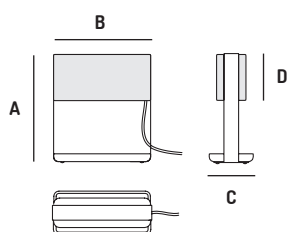
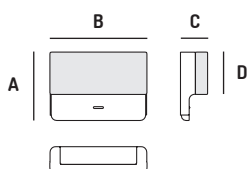

ref	TYPE	A	B	C	D	DIF BULB	A+
● QD.001.14N	TABLE LAMP	24 cm	21,5 cm	9,5 cm	10 cm	•	LED 4,5W 230V 2700K 370lm
○ QD.001.14W	TABLE LAMP	24 cm	21,5 cm	9,5 cm	10 cm	•	LED 4,5W 230V 2700K 370lm
● QD.002.14N	WALL LAMP with switch	15 cm	21 cm	6,5 cm	9 cm	•	LED 4,5W 230V 2700K 370lm
○ QD.002.14W	WALL LAMP with switch	15 cm	21 cm	6,5 cm	9 cm	•	LED 4,5W 230V 2700K 370lm
● QD.003.14N	WALL LAMP without switch	15 cm	21 cm	6,5 cm	9 cm	•	LED 4,5W 230V 2700K 370lm Dimmable TRIAC
○ QD.003.14W	WALL LAMP without switch	15 cm	21 cm	6,5 cm	9 cm	•	LED 4,5W 230V 2700K 370lm Dimmable TRIAC

CE IP20 QD.001.14N, QD.001.14W

CE IP20 QD.002.14N, QD.002.14W, QD.003.14N, QD.003.14W

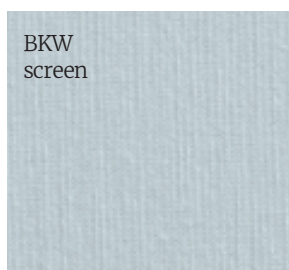
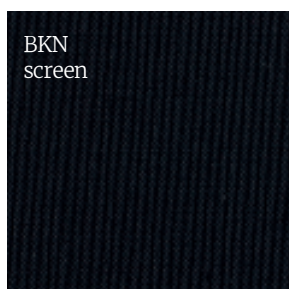





Twice

by Crous Calogero,
(Francesc Crous and Alessandro Calogero)



Discreet and minimalist, a comfortable wall lamp that provides light for reading, ease of movement, and a soft arc of light, essential for preparing to rest.

This two-in-one lighting accessory offers a choice of colour and texture for the shade that best adapts to the ambience.

Discreto y minimalista, es un cómodo aplique que proporciona luz directa para la lectura, y con un sencillo movimiento, su suave arco de luz esencial prepara para el descanso.

Este accesorio lumínico dos en uno permite elegir la pantalla del color y la textura que mejor se adapte al ambiente.

Wall lamp with a lacquered metal structure in white and shade available in any material in group A. 360° adjustable LED light source. Switch and integrated USB charger socket.

Aplique con estructura metálica lacada en blanco y pantalla disponible en cualquier material grupo A. Fuente de luz LED orientable 360°. Interruptor y salida de cargador USB integradas.

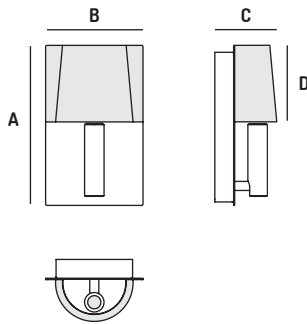

ref	TYPE	A	BØ	C	D	DIF	BULB A+
TW.001.14	WALL LAMP	23 cm	14 cm	9 cm	11 cm		LED 1,5W 500mA 2700K 180lm

CE IP20



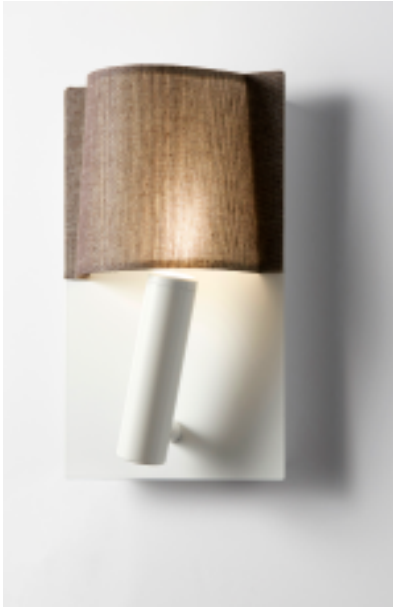

Materials



Group A
Grupo A

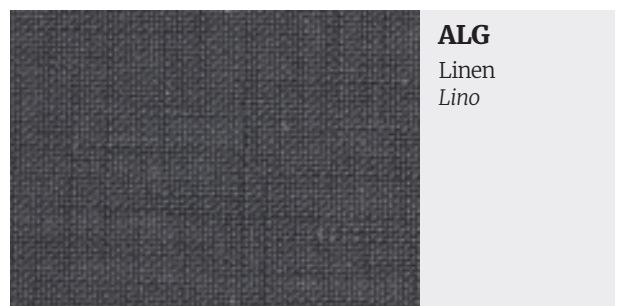
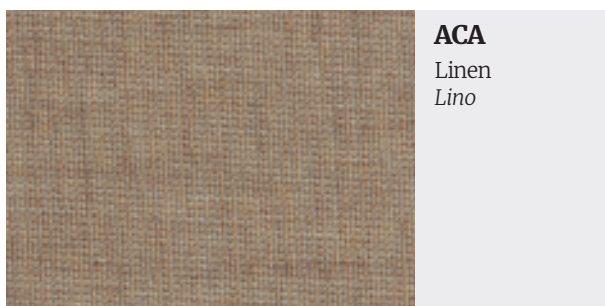
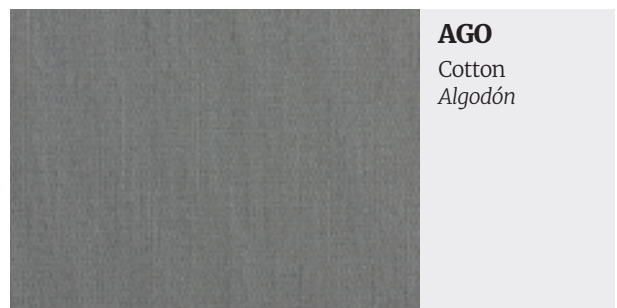
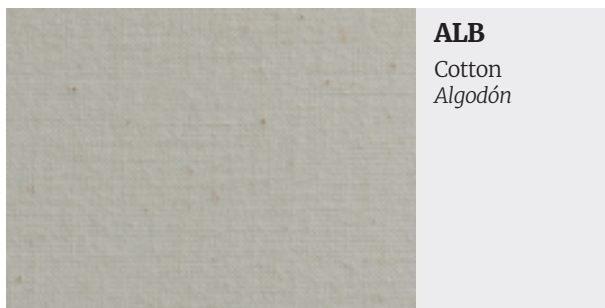
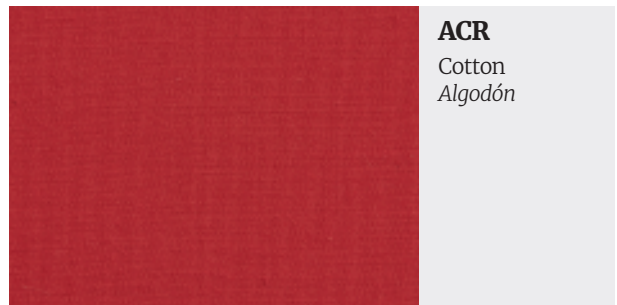
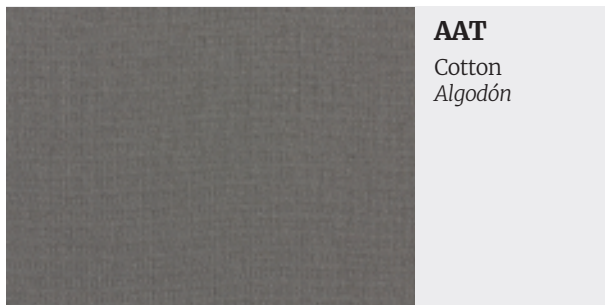
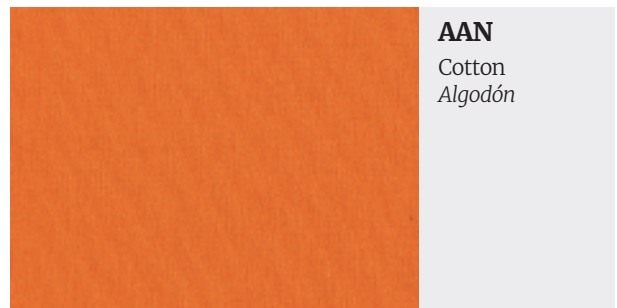
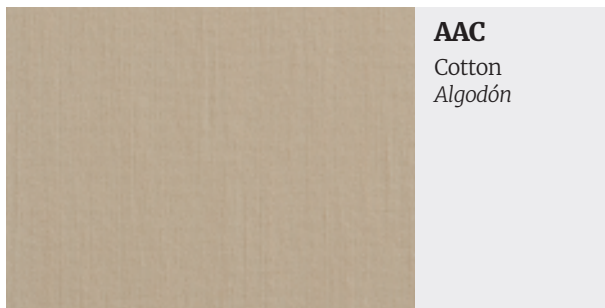

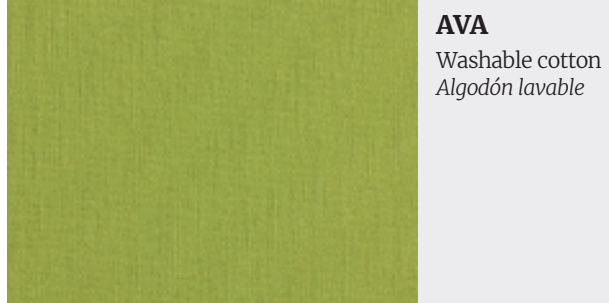

AVA
Washable cotton
Algodón lavable

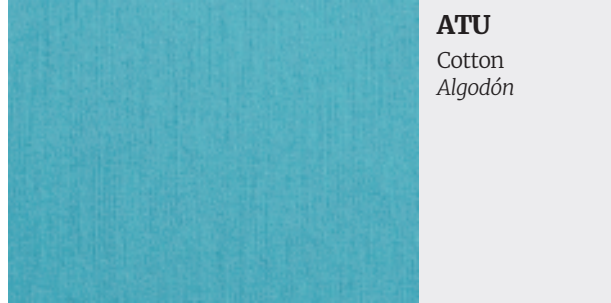

ATU
Cotton
Algodón

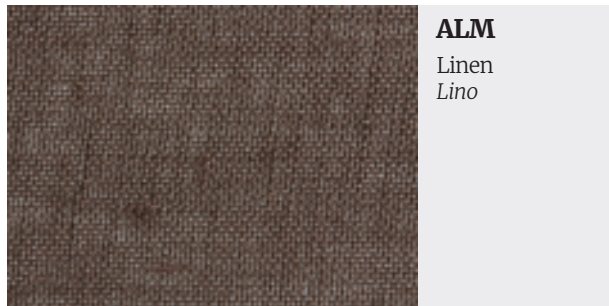

ALM
Linen
Lino

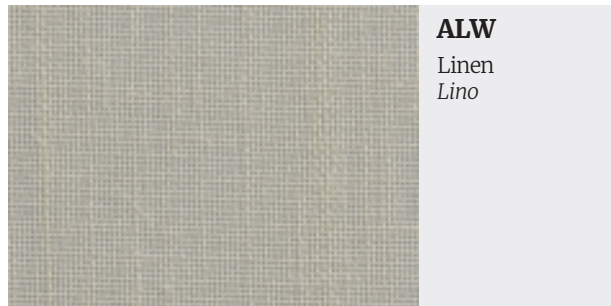

ALW
Linen
Lino



ALX
Linen
Lino

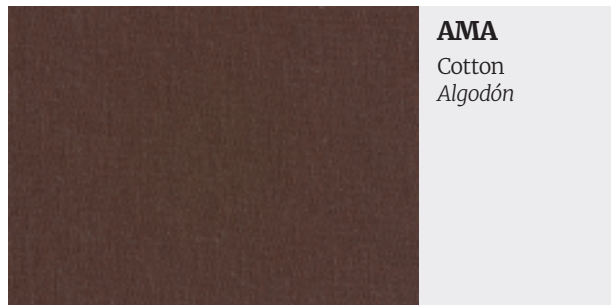

AMA
Cotton
Algodón

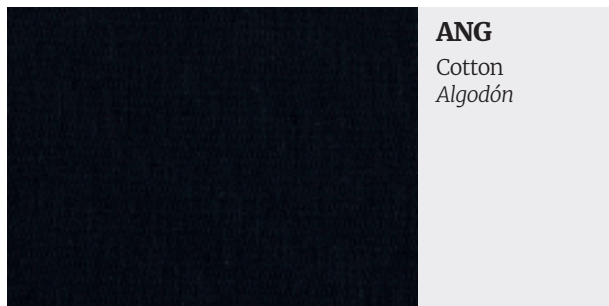

ANG
Cotton
Algodón

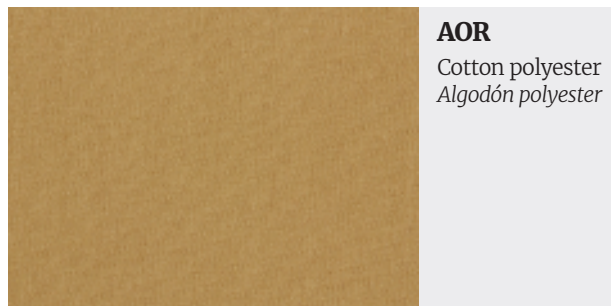

AOR
Cotton polyester
Algodón polyester

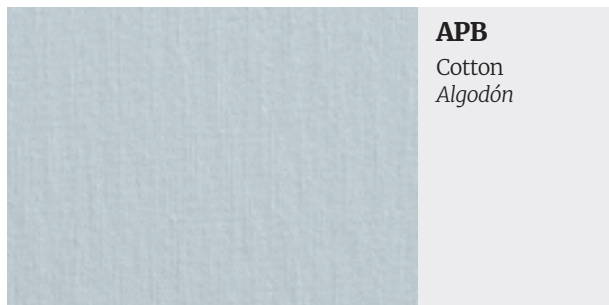

APB
Cotton
Algodón



APX
Washable
Perlasilk
*Lavable
Perlasilk*

All El Torrent Il·luminació, sl. products are manufactured according to European regulations UNE-EN 60598-1:2015

The main part of collection are ETL listed.

El Torrent Il·luminació, SL. reserves the right to make any changes it believes are beneficial to the end product and are in the client's interests. The content of this catalogue is copyright protected.

Total or partial reproduction of the images, text, illustrations, and graphic designs included this catalogue is categorically forbidden without the express authorization of El Torrent Il·luminació, SL.

Todos los productos de El Torrent Il·luminació, S.L. están fabricados siguiendo las normativas europeas UNE-EN 60598-1:2015.

La mayoría de las colecciones cumplen la normativa ETL

El Torrent Il·luminació, S.L. se reserva el derecho de hacer los cambios que considere oportunos en beneficio del producto final y del cliente. Todo el contenido de este catálogo está protegido por derechos de autor y copyright.

Queda terminantemente prohibida la reproducción total o parcial de las imágenes, textos, ilustraciones y conceptos gráficos sin autorización expresa de El Torrent Il·luminació, S.L.



Design Diseño

www.cel-lula.com

Photography Fotografía

starpestudi.com

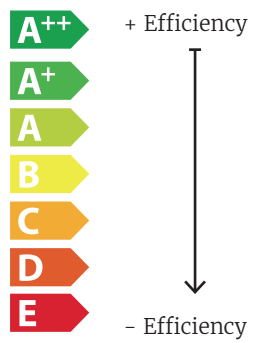

The energy efficiency categories include several types of lamp for reference purposes. Due to a rapidly changing market and the differences between manufacturers we use energy efficiency categories as a guide.

Los intervalos incluyen varias categorías de lámparas como referencia. Debido a los rápidos cambios en el mercado y las diferencias entre fabricantes, utilizamos intervalos como guía.



el**torrent**

nowoline[®]

inszeniert licht

novoline ag
flughofstrasse 56 ch - 8152 glattbrugg

fon 044 / 874 20 20
fax 044 / 874 20 30
mail info@novoline.ch
net www.novoline.ch

planung • beratung • herstellung • vertrieb