

Lzf

“WOOD TOUCHED BY LIGHT”

since 1994

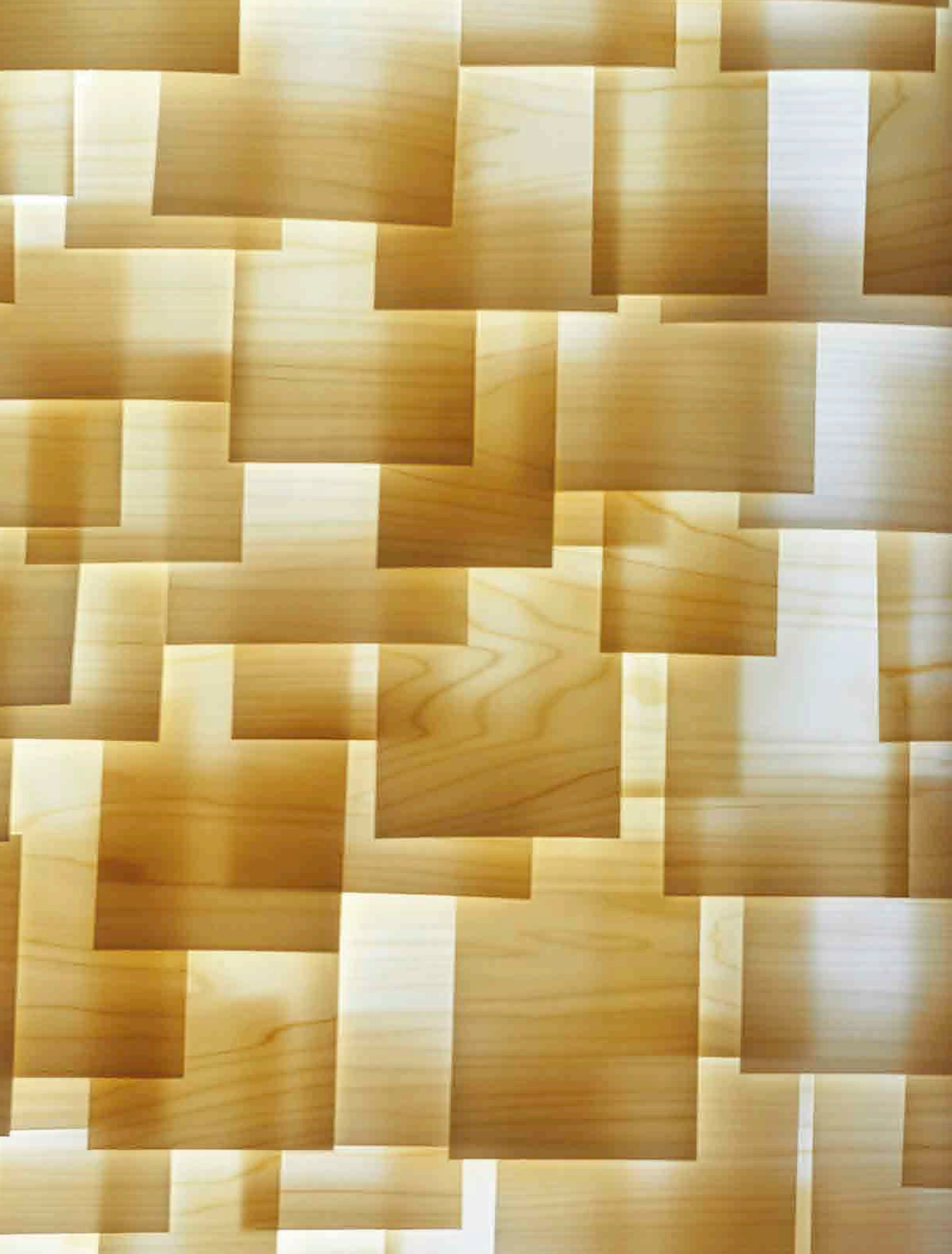







Unique Handmade Wood Veneer Lighting

Since 1994

CONTENTS

LZF NOW / 7
ALPHABETICAL GUIDE / 9
THE COLLECTION / 15
THE LIFE SIZE COLLECTION / 473
WOOD SHADE FINISHES / 521
TECHNICAL DATA / 527
DESIGNERS & PRODUCT YEARS / 575
CREDITS / 579

Every day thousands of LZF lamps are switched on around the world

LZF is a story of people, wood and light and the result of a peculiar encounter between two strangers. When they met, they both loved their hands and what they were capable of doing with them. Both shared a passion for the arts, for ideas, and experimenting. They coincided in their way of living and their very distinct view of the world. With an absolute belief that everything you feel can be materialised, they began to experiment. Till one night, playing with some wood veneers, they managed to envelop light. LZF was born.

It was in 1993 when these two strangers met. She was a painter, arriving back in Spain having left New York: her name was Mariví Calvo. He was an Australian musician discovering Spain: his name was Sandro Tothill. Strangers have the ability to alter our lives and it is on that day they cease to be strangers. These things do not happen every day. These were the days during which they began to sketch the essence of what is now the atmosphere of LZF.

Wood is a the noble and natural part of LZF lamps. It is all FSC certified, ensuring its origin from controlled forests and guaranteeing its sustainability and environmental commitment.

LZF lamps' wood veneers are treated with Timberlite®, a technique patented by LZF that allow this fragile material to become flexible and resistant without the need of any chemical processes.

LZF spreads its passion for lighting and today more than a dozen multifaceted designers from around the world have already designed an LZF lamp.

Today, LZF is an international brand recognised for its details and its clear and differentiated image. LZF designs experiences through the use of light, where people and spaces mix, creating their own unique atmosphere. Designers, craftspersons, engineers, architects, consultants and interior designers make up the internal engine behind the creation of these experiences, guaranteeing that each one has its own unique personality.

Their lamps illuminate thousands of spaces and accompany millions of people. Each of these lamps is made by hand, with the same passion of enveloping the light that Marivi and Sandro began with on that afternoon so many years ago.

The book that you hold in your hands collects the thoughts, aesthetics and discoveries cultivated throughout LZF's many years. We invite you to know their stories and through them, to share their vision of life.

Welcome.

ALPHABETICAL GUIDE

A

Agatha / 19
Air / 43
Asterisco / 59

B

Banga / 71

C

Candelabro / 83
Carambola / 93
Cervantes / 107
Chou / 121
Cuad / 135

D

Dandelion / 145
Domo / 157

E

Escape / 169

G

Gea / 185
Guijarros / 203

H

Hi-Collar / 211

I

I-Club / 221
Icon / 243

K

Kim / 253

L

Link / 265
Link Chain / 283
Link Modular / 291

M

MiniMikado / 297

N

New Wave / 307
Nut / 319

O

Orbit / 329

P

Piknik / 339
Pleg / 349
Pod & Poppy / 359

R

Raindrop / 371
Romanica / 381

S

Saturnia / 393
Screen / Paisley / 407
Spiro / 417
Stitches / 429
Swirl / 445

T

Totem / 459

X

X-Club / 473

LIFE SIZE

Elephant / 487
Fish / 499
Koi / 509

Wood shade
finishes / 521

Technical
data / 527

SUSPENSION

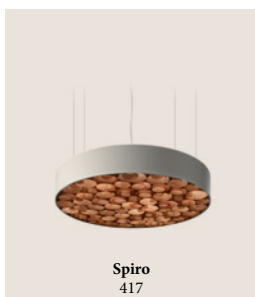
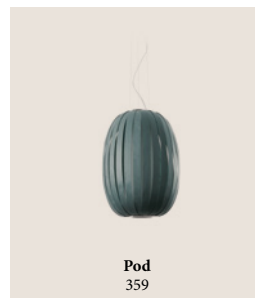
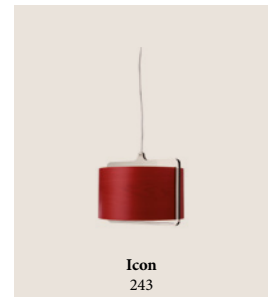
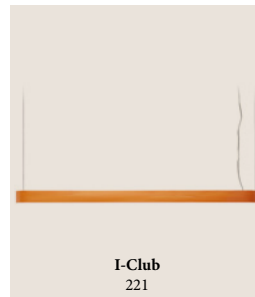
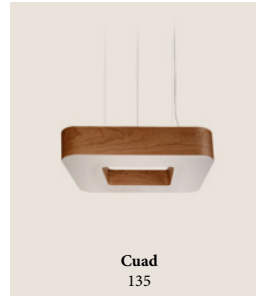



Banga
71



Banga
71



Carambola
93



Cervantes
107



Dandelion
145



Domo
157



Link Chain & Modular
283



Escape
169



Kim
253



Link
265



MiniMikado
297



Raindrop
371



Romanica
381



Totem
459



Saturnia
393



Stitches Djenné
429

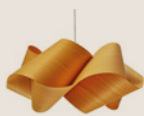

Swirl
445



X-Club
473

TABLE

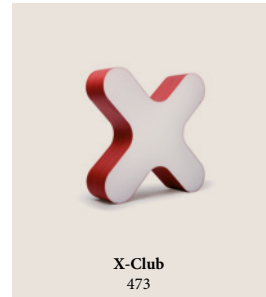
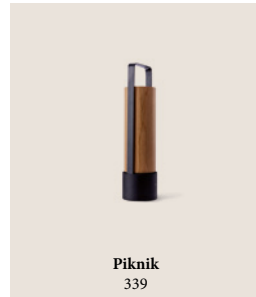

WALL

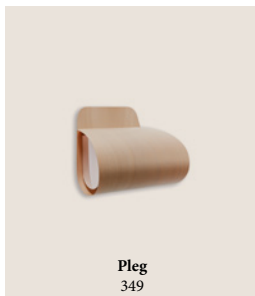
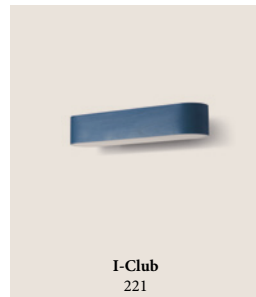

**WALL
&
CEILING**

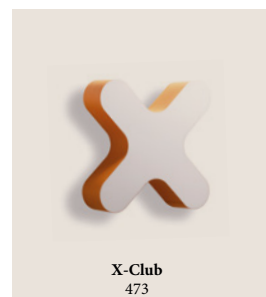

FLOOR



Cosmos
175

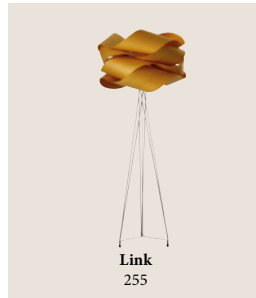

Link
255

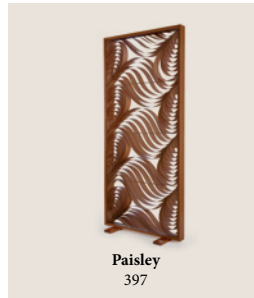

Paisley
397

LIFE SIZE



Fish
499



Elephant
487

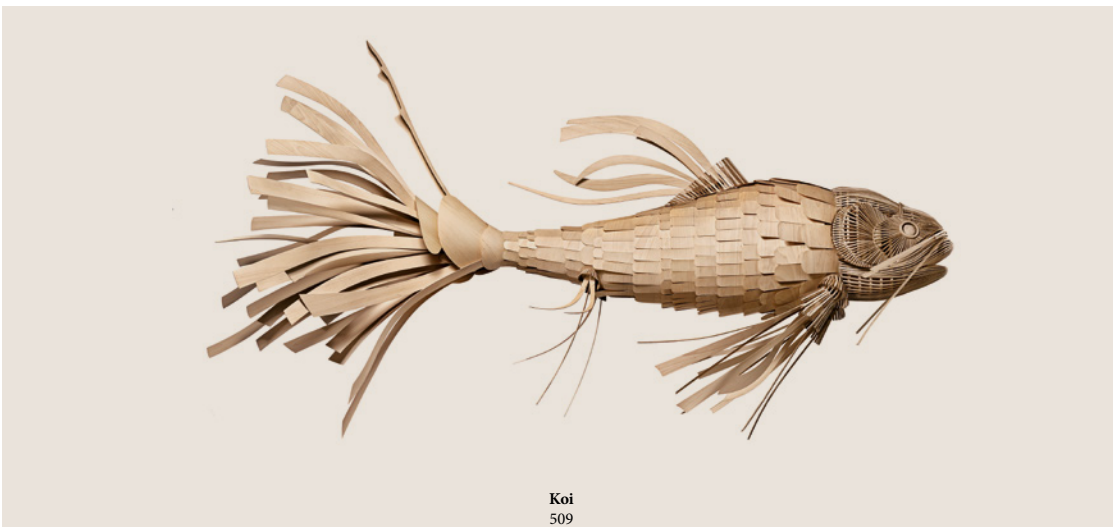

Koi
509

THE COLLECTION

1994 -2017

I.

“Why all the mystery?” Jack asked, surprised.
“It’s a present,” I responded.

—¿Por qué tanto misterio? —interrogó Jack sorprendido.
—Es un regalo —le respondí.





AGATHA

LUIS ESLAVA STUDIO

FAMILY

SUSPENSION

TECHNICAL DATA

SEE PG. **531**



ATA SB-20 Palau de Casavells. Art, Antiques, Design, Architecture. Girona, Spain.

AGATHA SUSPENSION BALL

Ref. ATA SB

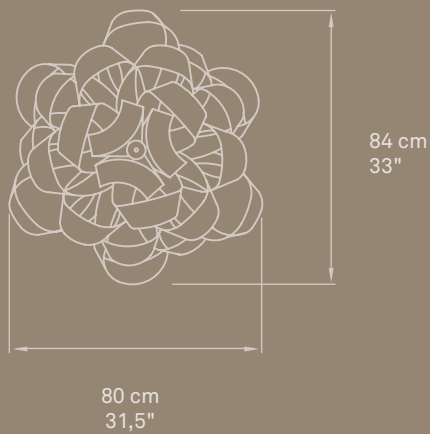
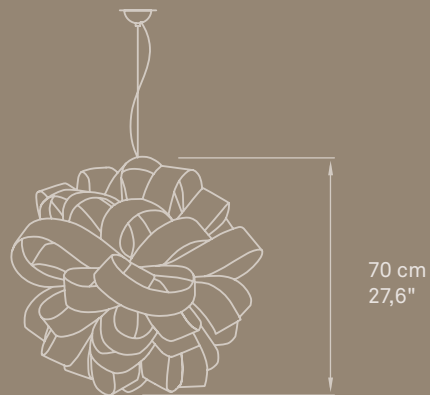



ATA SB-20 Villa El Nido. Architects: A-cero. Marbella, Spain.





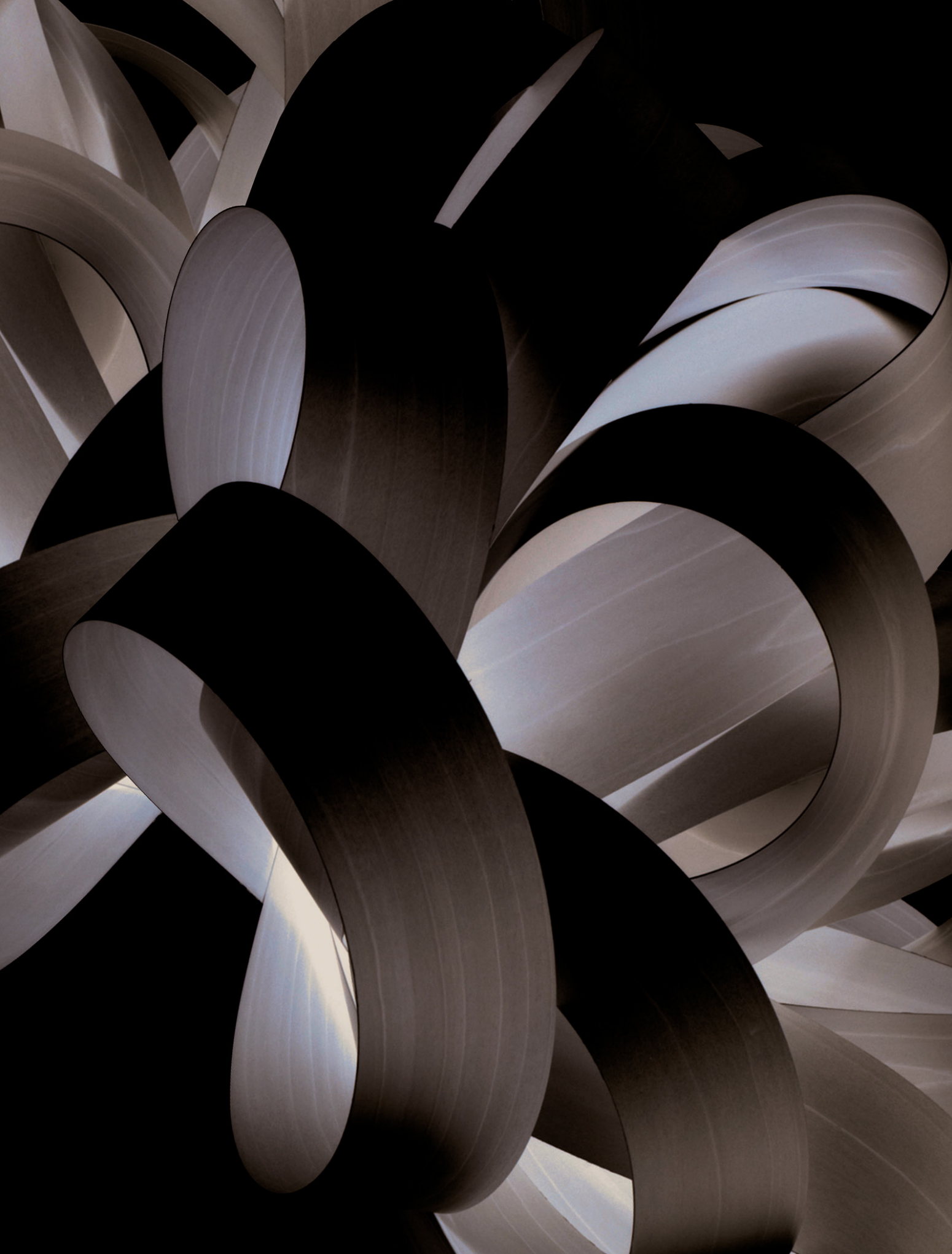



ATA SG-22 Library, Los Gatos, California. Noll & Tam Architects. Lighting Designer Illuminosa.

AGATHA LARGE SUSPENSION

Ref. ATA SG

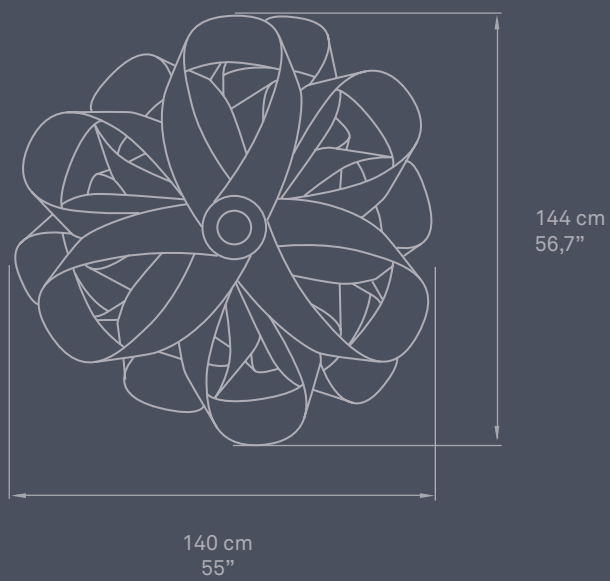
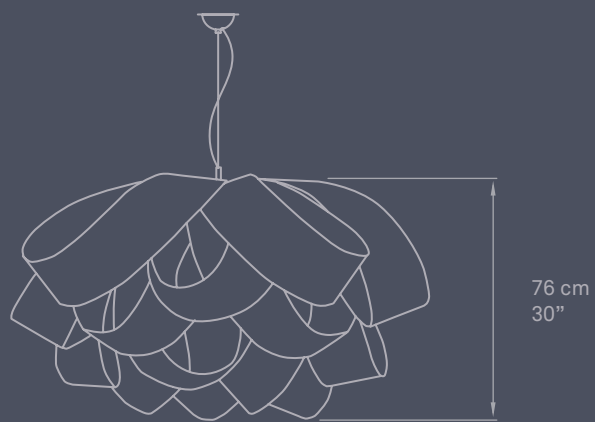



ATA SG-20 Palau de Casavells. Art, Antiques, Design, Architecture. Girona, Spain.





ATA SG-20 Villa El Nido. Architects: A-cero. Marbella, Spain.





AGATHA SMALL SUSPENSION

Ref. ATA SP

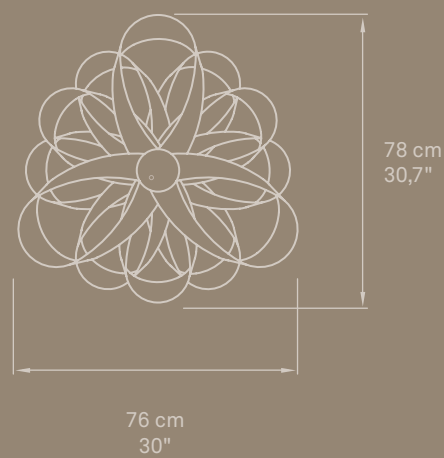
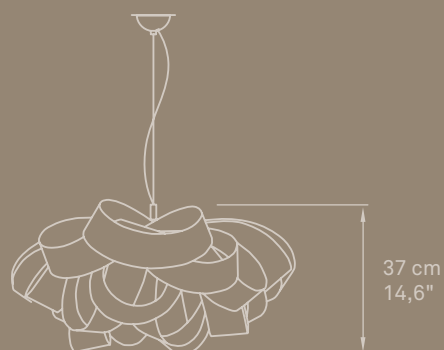



ATA SP-26

Project:
House Forest
Lodge

Location:
Sydney

Architects:
Carterwilliamson
Architects

Photography:
Brett Boardman



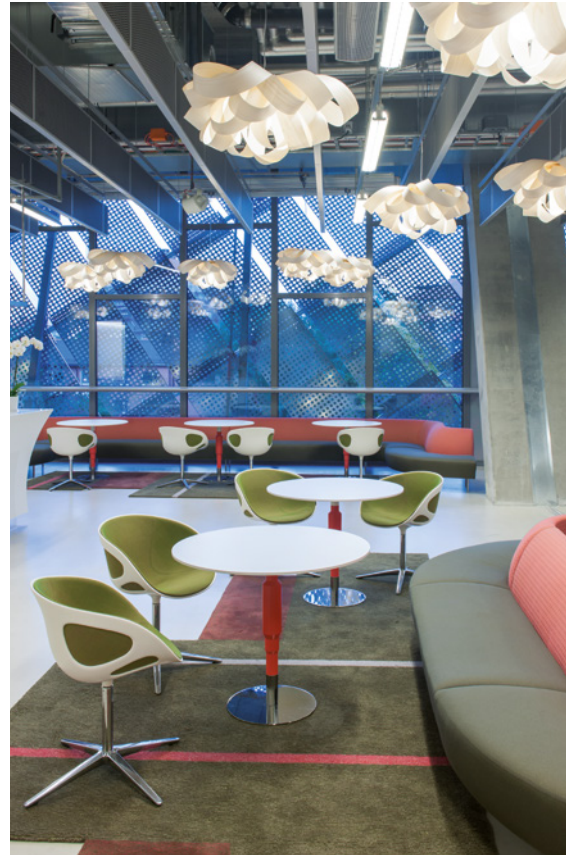
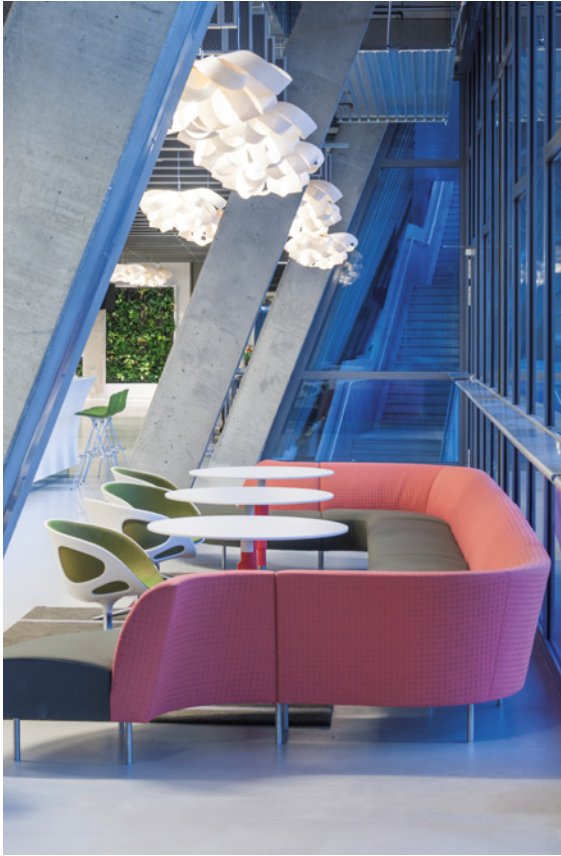

ATA SP-20

Project:
Tele2 Arena
stadium

Location:
Sweden

**Interior
Designers:**
InPut interior







II.

“Imagine that the law of gravity doesn’t exist,”
Professor Hoover remarked.
We then spent the rest of the evening staring at the fire.

—Imagine que no existe la ley de la gravedad —propuso el
profesor Hoover. Luego, nos quedamos mirando el fuego de la
chimenea el resto de la velada.



AIR

RAY POWER

FAMILY

WALL / TABLE

TECHNICAL DATA

SEE PG. **532**



AIR TABLE

Ref. AIR MG

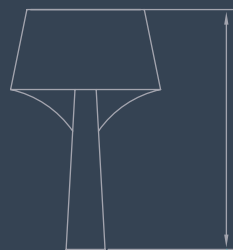

49 cm
19,3"

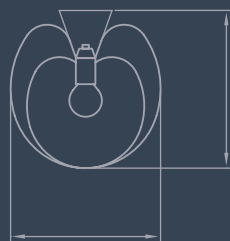

28 cm
11"

27 cm
10,6"





AIR MG-20 Palau de Casavells. Art, Antiques, Design, Architecture. Girona, Spain.



AIR A-20 Caro Hotel, Valencia, Spain.

AIR WALL

Ref. AIR A

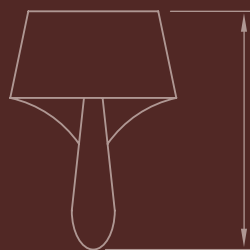

33 cm
13"

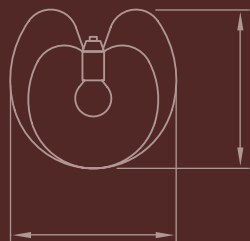

22 cm
8,7"

23 cm
9"







AIR A-29 La Monella Jewelers. Valencia, Spain.





AIRA-21



III.

“Don’t forget that last verse of the poem,” she said.

“I wrote it down on a piece of paper,” he replied.

“Make sure you don’t lose it.”

—No vaya a olvidarse del último verso del poema.

—Lo he anotado en un papelito.

—No vaya a perder el papelito.



ASTERISCO

CUATRO CUATROS
TABLE

TECHNICAL DATA
SEE PG. **532**



AST M W-22 Villa El Nido. Architects: A-cero. Marbella, Spain.

ASTERISCO

TABLE

Ref. AST M

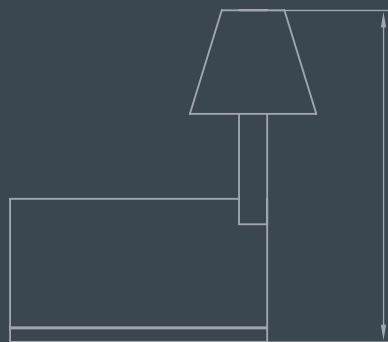

56 cm
22"

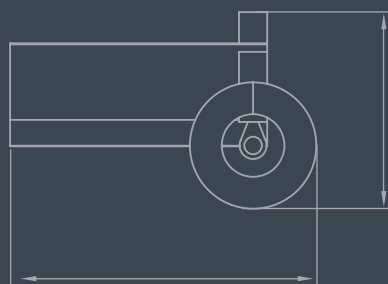

32 cm
12,6"

50 cm
19,7"



AST M AL-20 Palau de Casavells. Art, Antiques, Design, Architecture. Girona, Spain.





AST M W-21

Project:
Palau Gea Studio

Location:
Valencia, Spain



ASTM AL-21 Villa El Nido. Architects: A-cero. Marbella, Spain.



IV.

“What are you doing?” he said, not knowing much about her.

“I’m building a boat,” she replied. “Summer starts tomorrow.”

“I’d forgotten,” he said.

—¿Qué hace? —seguía sin saber mucho de ella.

—Construyo una barca? Mañana empieza el verano.

—Lo había olvidado.



BANGA

YONOH CREATIVE STUDIO

FAMILY
SUSPENSION

TECHNICAL DATA
SEE PG. **533**



BNGA SM LED-24 Le Meridien Hotel. Tarragona, Spain.

BANGA

MEDIUM SUSPENSION

Ref. BNGA SM LED

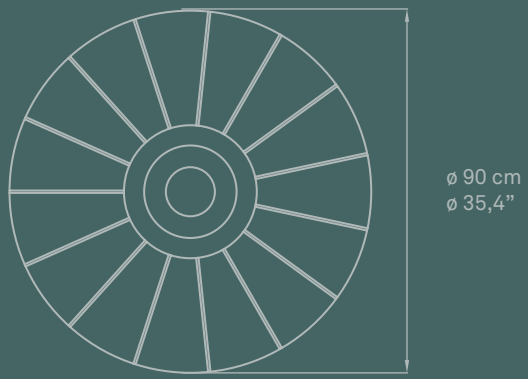
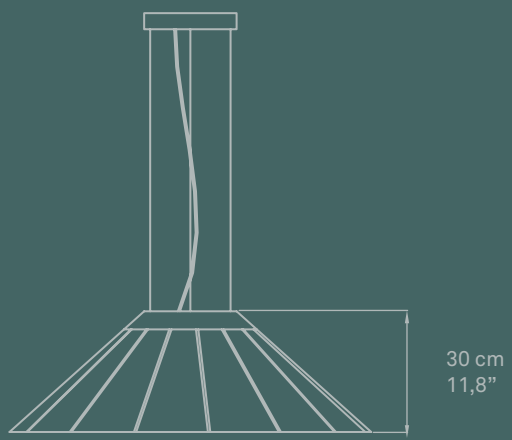



BNGA SG LED-26 Le Meridien Hotel. Tarragona, Spain.

BANGA

LARGE SUSPENSION

Ref. BNGA SG LED

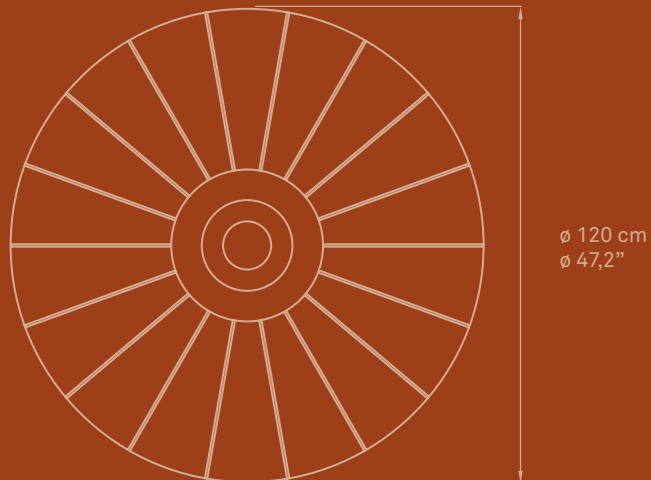
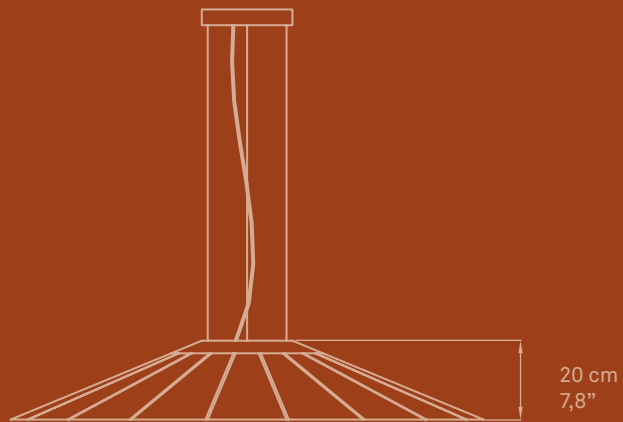



BNGA SG LED-32, BNGA SM LED-24, BNGA SM LED-29 Le Meridien Hotel, Tarragona, Spain.



HELMUT NEWTON
FASHION
HELMUT NEWTON Polaroids





V.

“Good morning Margaret. Did you rest well?”

“You could say so, I spent all night playing the piano.”

“Oh, was it you?”

—Buenos días, Margaret ¿ha descansado?

—Puede decirse que sí, he pasado la noche tocando el piano.

—¿Era usted?



CANDELABRO

MARIVÍ CALVO
SUSPENSION

TECHNICAL DATA
SEE PG. **534**



CLBO 15 LED-20 JMM shop, Valencia, Spain.

CANDELABRO

SUSPENSION

Ref. CLBO 15 LED

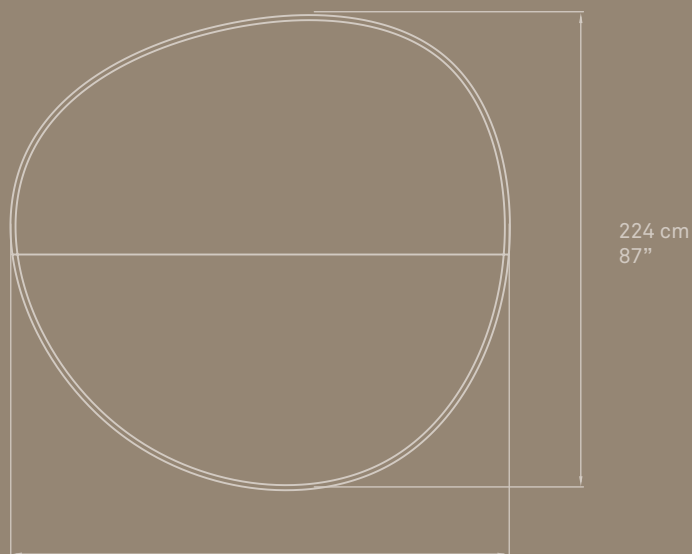
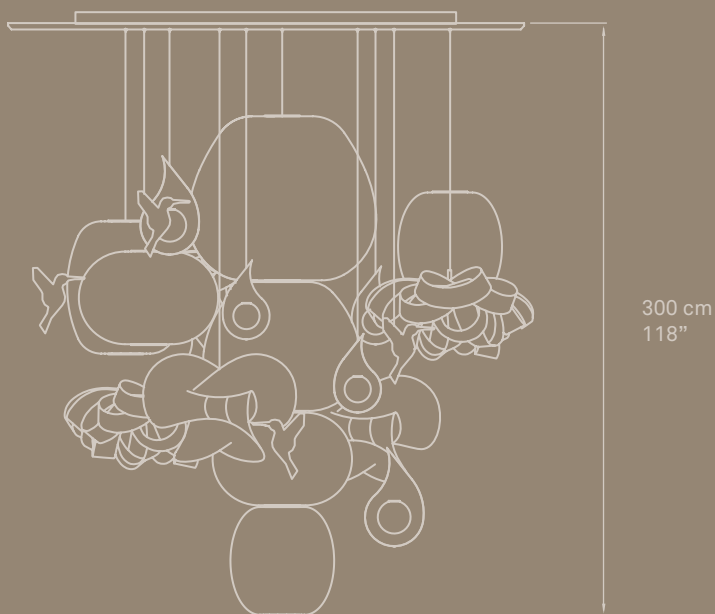

236 cm
96,5"



CLB015 LED-20/22

Project:
Villa π

Location:
Osijek, Croatia

Architects:
Oliver Grigic





CLBO 15 LED-20

Project:
NH Abascal Hotel

Location:
Madrid

Architects:
Proffetional



VI.

“Make a wish,” she said. “Have you made it?”
“I wished for them all,” which was true, and we all
started laughing.

—Pide un deseo —me ha dicho—. ¿Ya lo has pedido?

—He pedido todos —era verdad, y nos hemos echado a reír.



CARAMBOLA

OSKAR CEREZO

FAMILY

SUSPENSION / TABLE

TECHNICAL DATA

SEE PG. **535**



CAR SM-21

CARAMBOLA

MEDIUM SUSPENSION

Ref. CAR SM

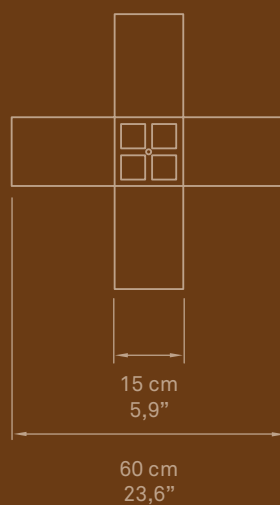
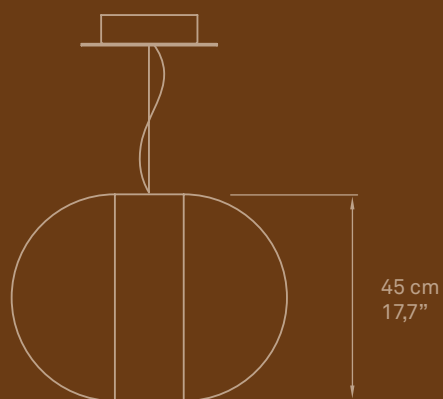



CAR SP-29 La Monella Jewelers. Valencia, Spain.

CARAMBOLA SMALL SUSPENSION

Ref. CAR SP

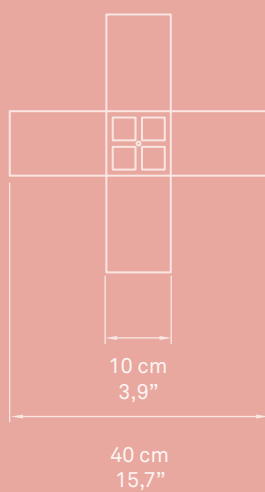
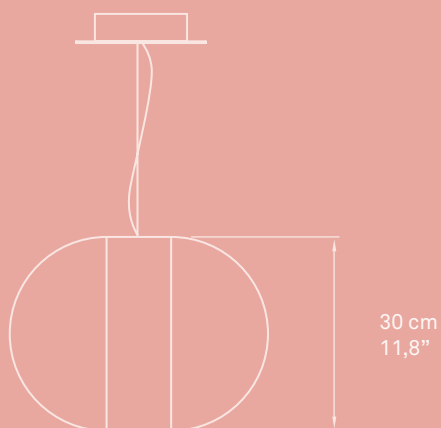



CAR SP-21 Villa El Nido. Architects: A-cero. Marbella, Spain.





CAR M-21 Palau de Casavells. Art, Antiques, Design, Architecture. Girona, Spain.

CARAMBOLA

TABLE

Ref. CAR M

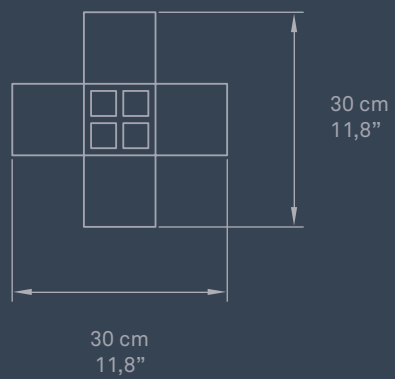





VII.

“Do you know of anything more beautiful than mathematics?” he asked, and for a minute I wasn’t sure if this was a question or a challenge.

“Yes,” I replied, “of course I do.”

—¿Conoce algo más bello que las matemáticas? —y yo no sabía si era una pregunta o un desafío.

—Sí —respondí—, claro.





CERVANTES

BURKHARD DÄMMER

FAMILY

SUSPENSION / WALL & CEILING

TECHNICAL DATA

SEE PG. **536**



CERV A BK LED-21 Ma Khin Cafe. Valencia, Spain.

CERVANTES

WALL & CEILING

Ref. CERV A LED

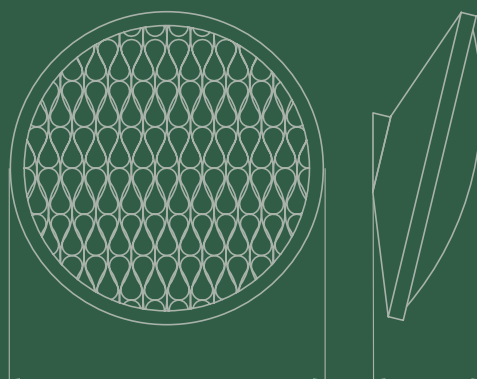

ø70 cm
ø27,5"

26 cm
10,3"

Ref. CERV AT LED

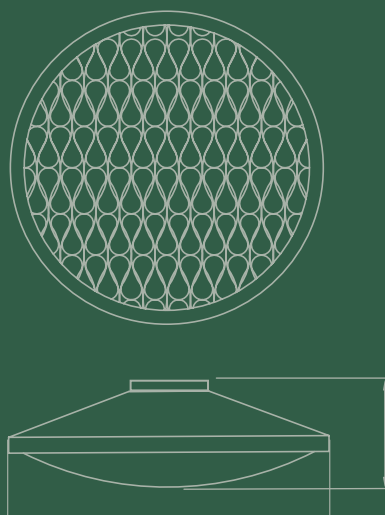

25 cm
9,8"

70 cm
27,5"







CERVS BK LED-21 Ma Khin Cafe, Valencia, Spain.

CERVANTES SUSPENSION

Ref. CERV S LED

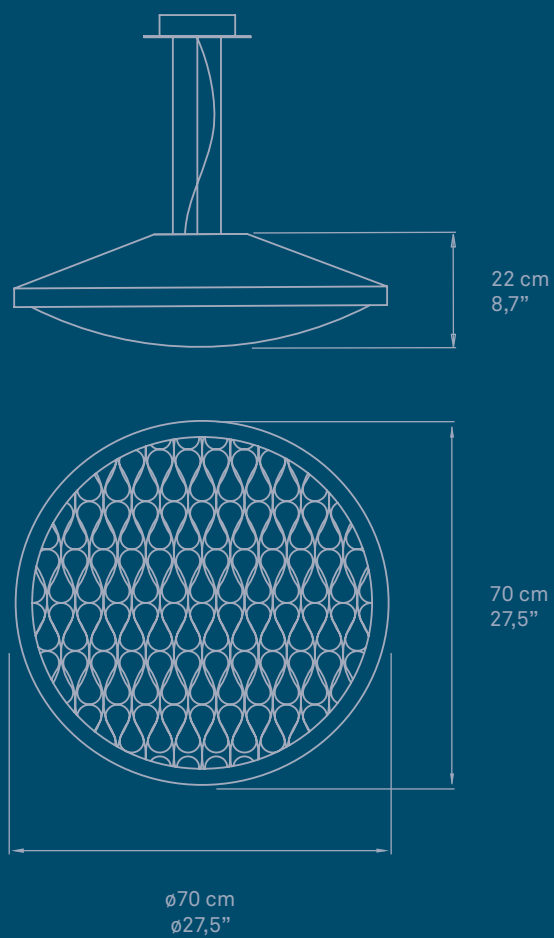



CERV S BK LED-21



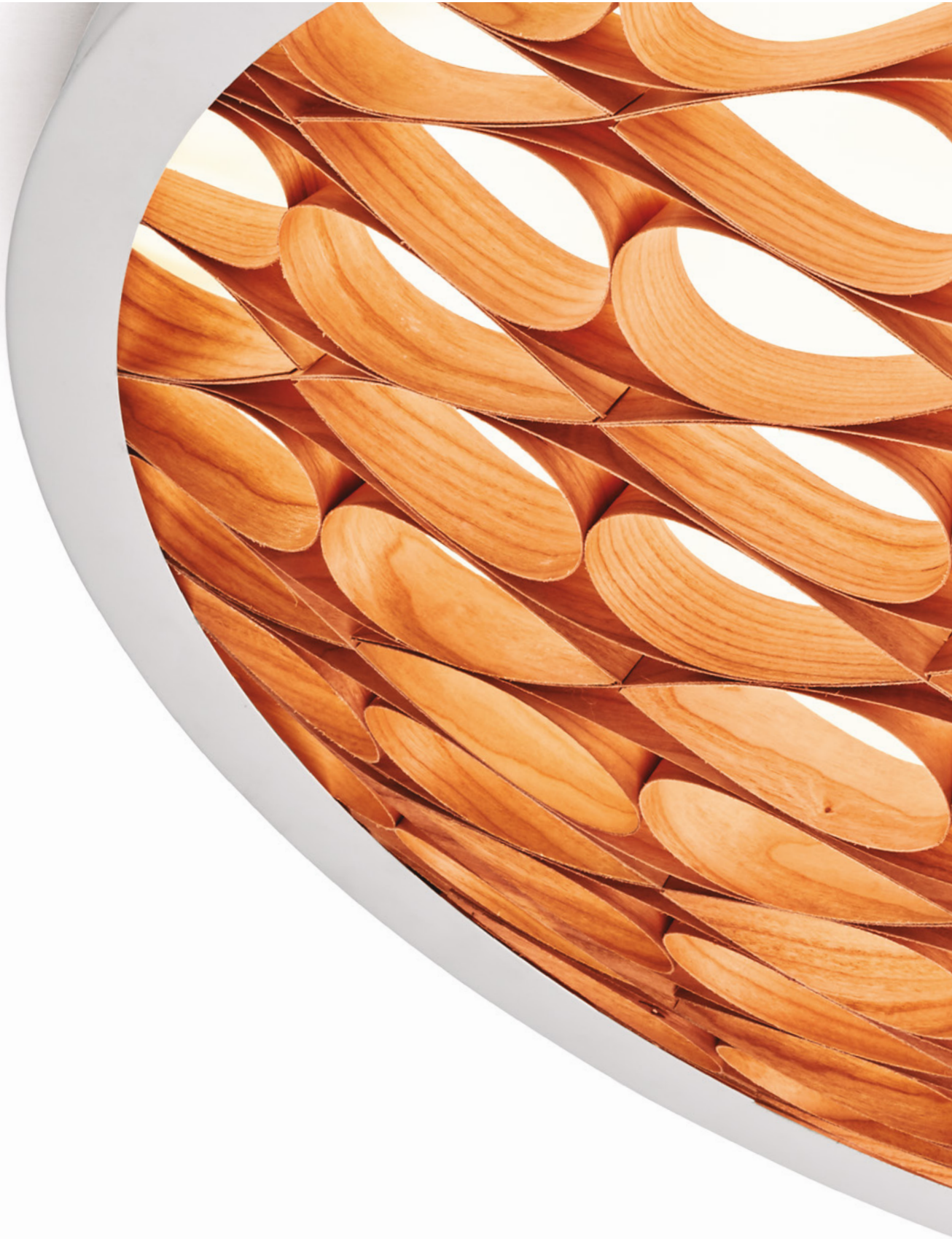

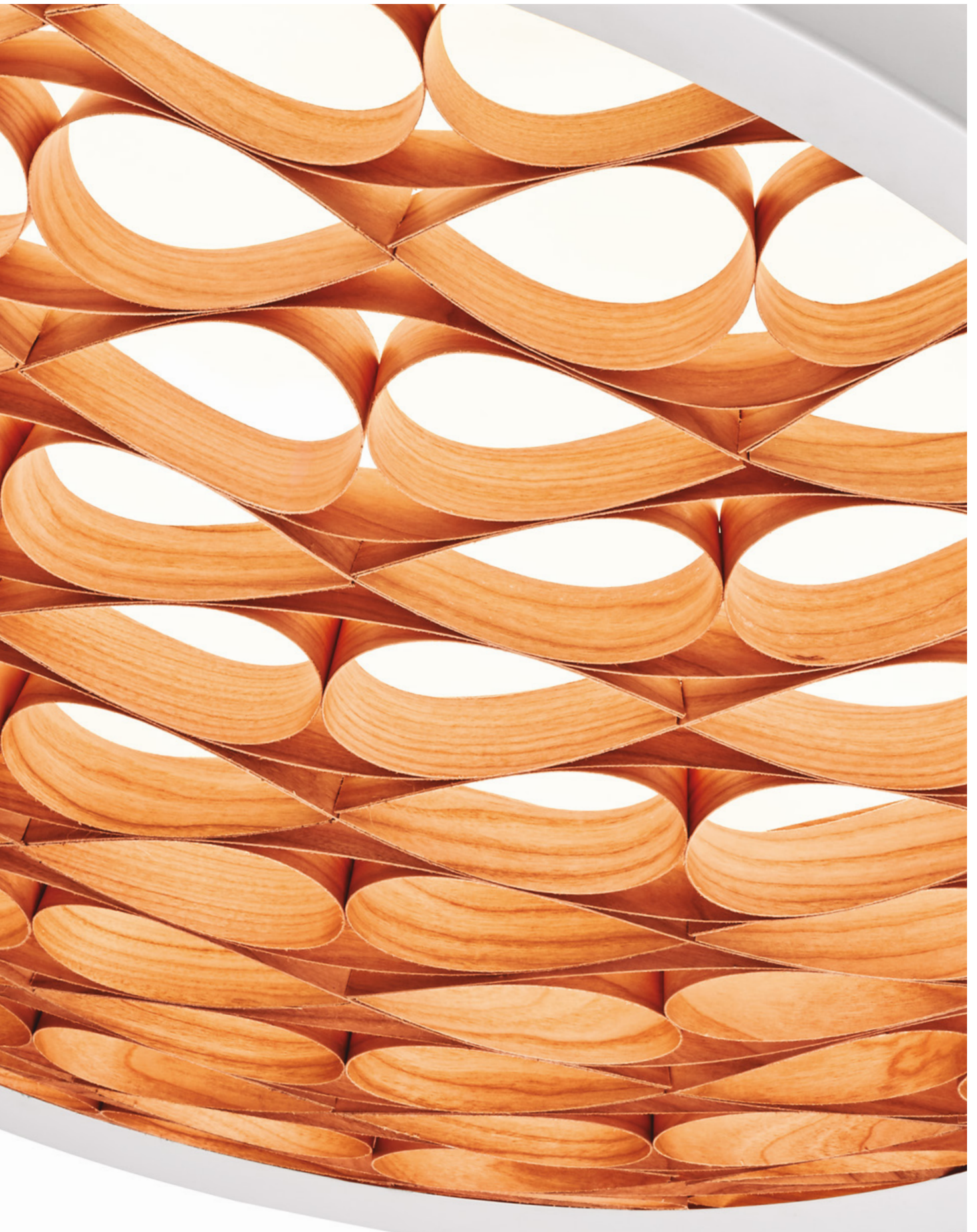

VIII.

“It was dark by the time we came out of the cinema,” Sally wrote in her diary, “then he invited me out and we ate fish near the harbour.”

—Cuando salimos del cine, había anochecido —escribió Sally en su diario—. Me invitó a comer pescado cerca del puerto.





CHOU

YONOH CREATIVE STUDIO

FAMILY

SUSPENSION / TABLE

TECHNICAL DATA

SEE PG. **537**



CHOU

SMALL/MEDIUM SUSPENSION

Ref.
CHOU SPA
CHOU SMA

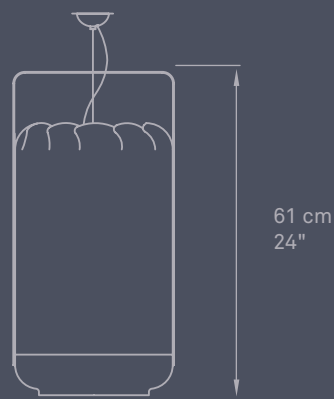
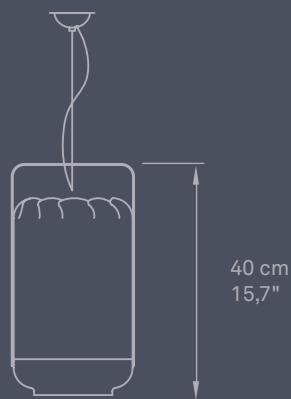

Ref.
CHOU SPB
CHOU SMB

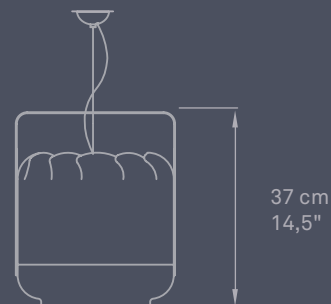
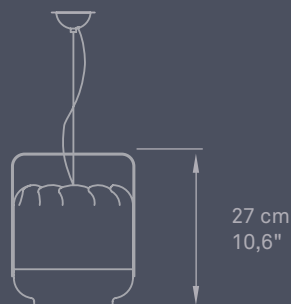



CHOU SMA-24, SPA-24, SMB-22



CHOU SPA-20, SPB-20 El Tilo de Sorní. Interior Desig: Cosín Estudio. Valencia, Spain.



CHOU MPB-30, MPA-24 Villa El Nido. Architects: A-cero. Marbella, Spain.

CHOU

SMALL/MEDIUM TABLE

Ref.
CHOU MPA
CHOU MMA

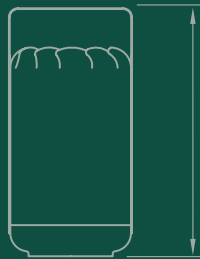

40 cm
15,7"

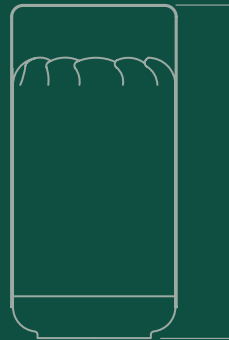

61 cm
24"



ø 21,5 cm
ø 8,4"



ø 30,5 cm
ø 12"

Ref.
CHOU MPB
CHOU MMB

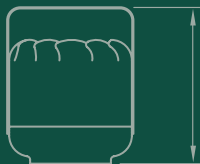

27 cm
10,6"

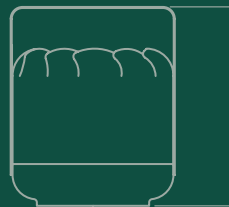

37 cm
14,5"



CHOU MMB-30 Palau de Casavells. Art, Antiques, Design, Architecture. Girona, Spain.



CHOU MMB-30





IX.

“Why do you move house so often?” Thelma asked me, a little worried.

“I like moving and reorganising everything back in their place again,” I replied.

—¿Por qué cambia tantas veces de casa? —me preguntó Thelma algo preocupada.

—Me gusta hacer mudanzas, volver a colocar cada objeto en su sitio.



CUAD

BURKHARD DÄMMER
SUSPENSION

TECHNICAL DATA
SEE PG. 539



CUAD SM LED-21 Villa El Nido. Architects. A-cero. Marbella, Spain.

CUAD SUSPENSION

Ref. CUAD SM LED

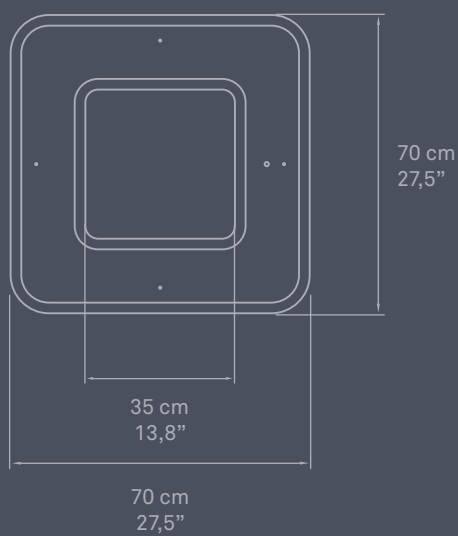
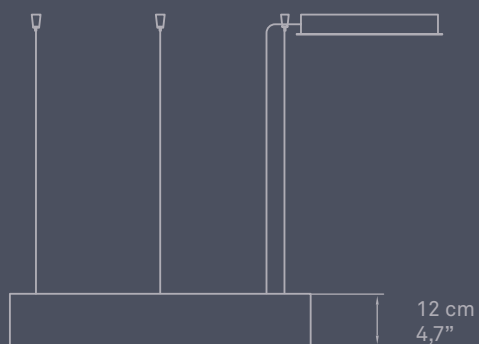



CUAD SM LED-21 Villa El Nido. Architects: A-cero. Marbella, Spain.







X.

“Do you know why the ocean never breaks?” she asked and I thought it was a joke.

“Because it’s made of molecules,” she continued. Julie never ceases to amaze me.

—¿Sabes por qué el océano no se rompe nunca? —pensé que era una broma.

—Porque está compuesto de moléculas —Julie no deja de sorprenderme.



DANDELION

BURKHARD DÄMMER
SUSPENSION

TECHNICAL DATA
SEE PG. **540**



DDLN S LED-26

DANDELION SUSPENSION

Ref. DDLN S LED

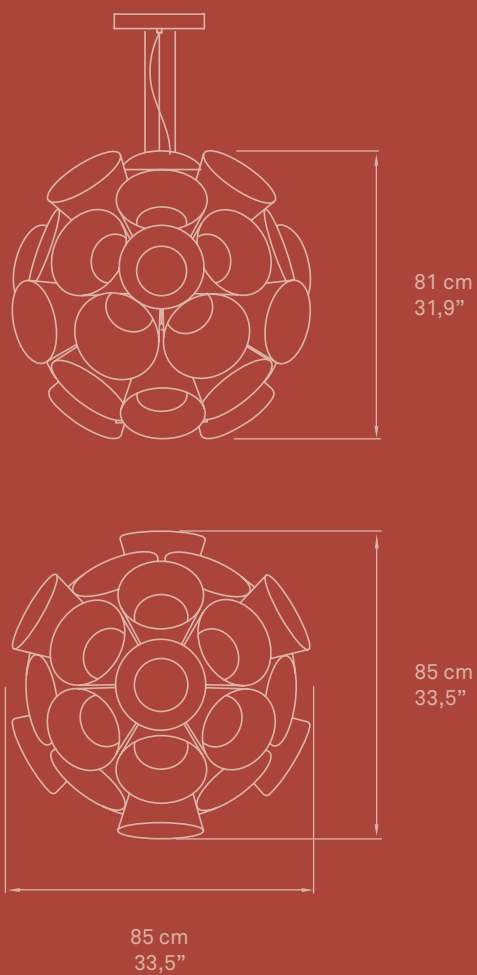



DDLN S LED-29 Le Meridien Hotel, Tarragona, Spain.



DDLN S LED-30 Palau de Casavells. Art, Antiques, Design, Architecture. Girona, Spain.



DDLN S LED-24 Palau de Casavells. Art, Antiques, Design, Architecture. Girona, Spain.







XI.

“There are flowers that only open their petals at night,” I said while he looked at me in incredulously.

“Every night,” I insisted.

—Hay flores que abren los pétalos de noche —afirmé, y me miró incrédulo.

—Todas las noches —insistí.



DOMO

RQR ESTUDIO
SUSPENSION

TECHNICAL DATA
SEE PG. **540**



DMO SG-21

DOMO SUSPENSION

Ref. DMO SG

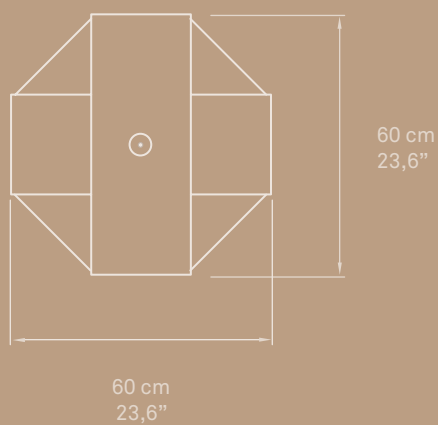
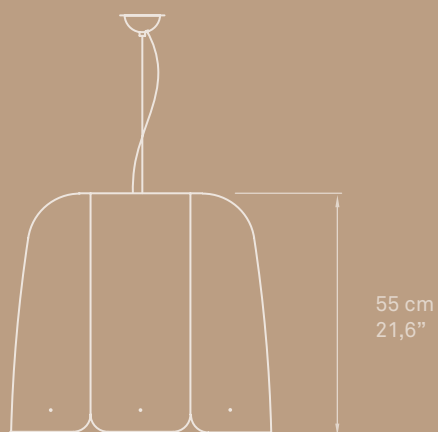



DMO SG-21 Palau de Casavells. Art, Antiques, Design, Architecture. Girona, Spain.





DMO SG-20







XII.

“I want to fly,” Susan said, “fly in a flock.”

—Quiero volar —dijo Susan— volar en bandada.



ESCAPE

RAY POWER

FAMILY

SUSPENSION

TECHNICAL DATA

SEE PG. **541**



ESCAPE SMALL SUSPENSION

Ref. SC SP

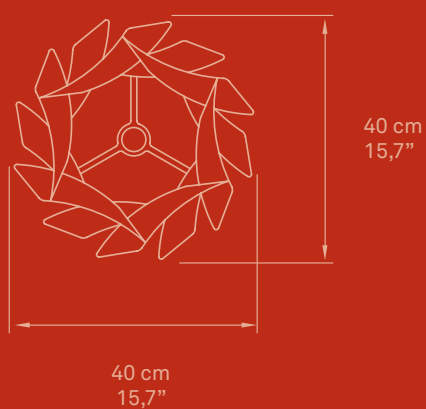
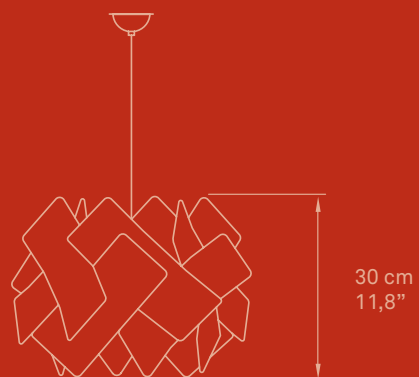



SC SP-28 Palau de Casavells. Art, Antiques, Design, Architecture. Girona, Spain.





ESCAPE LARGE SUSPENSION

Ref. SC SG

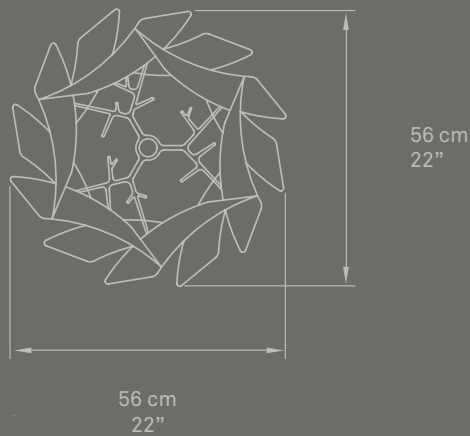
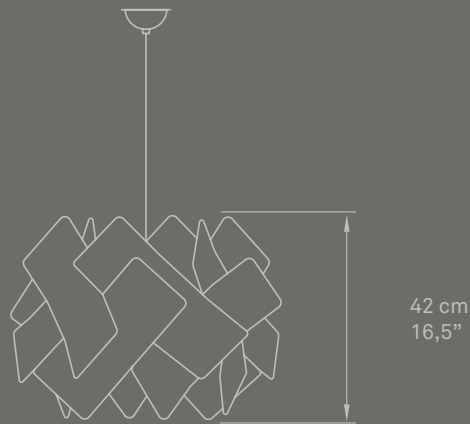



SC SG-20 Villa El Nido. Architects: A-cero. Marbella, Spain.







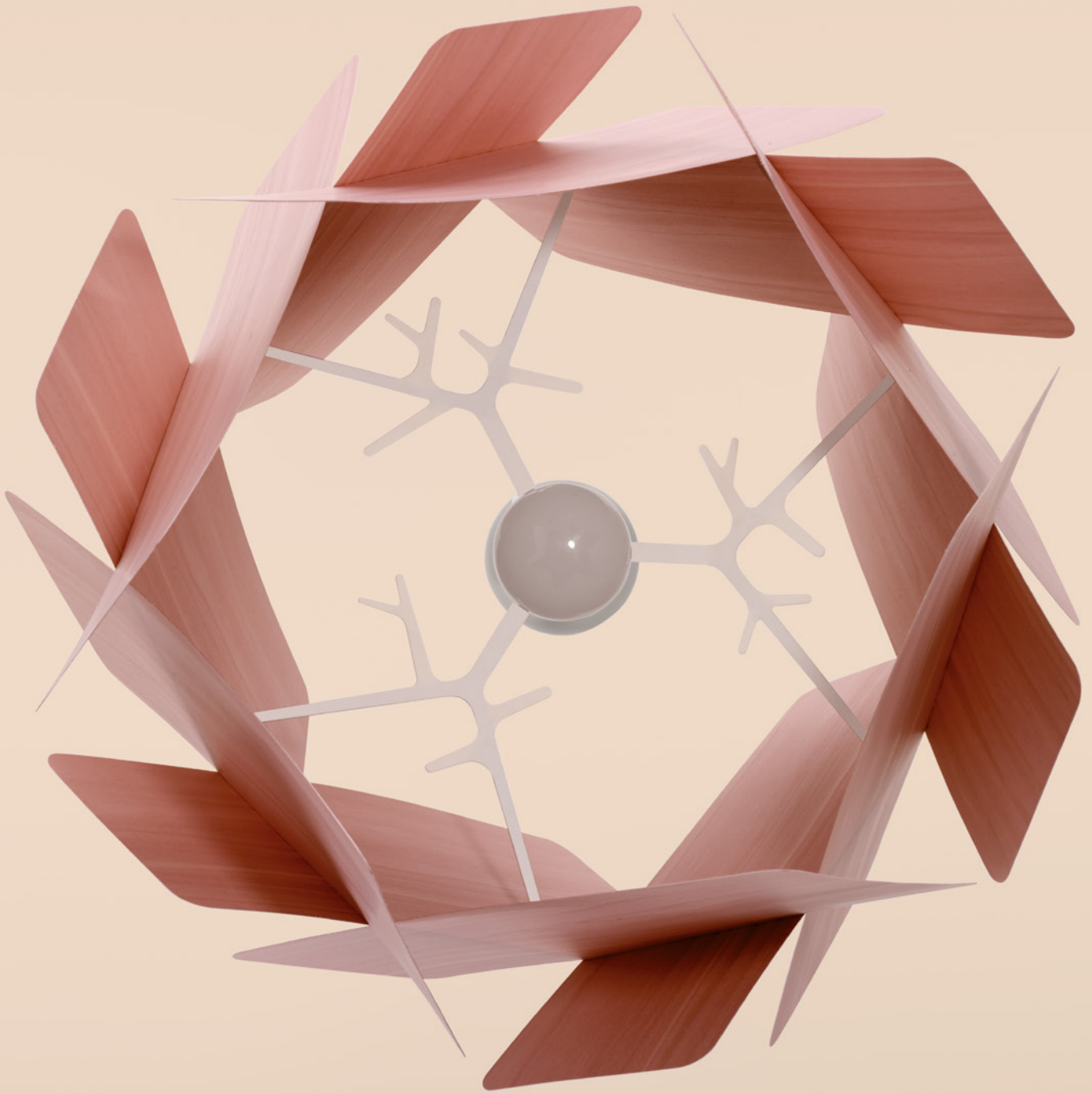

SC SG-32 (bottom view)

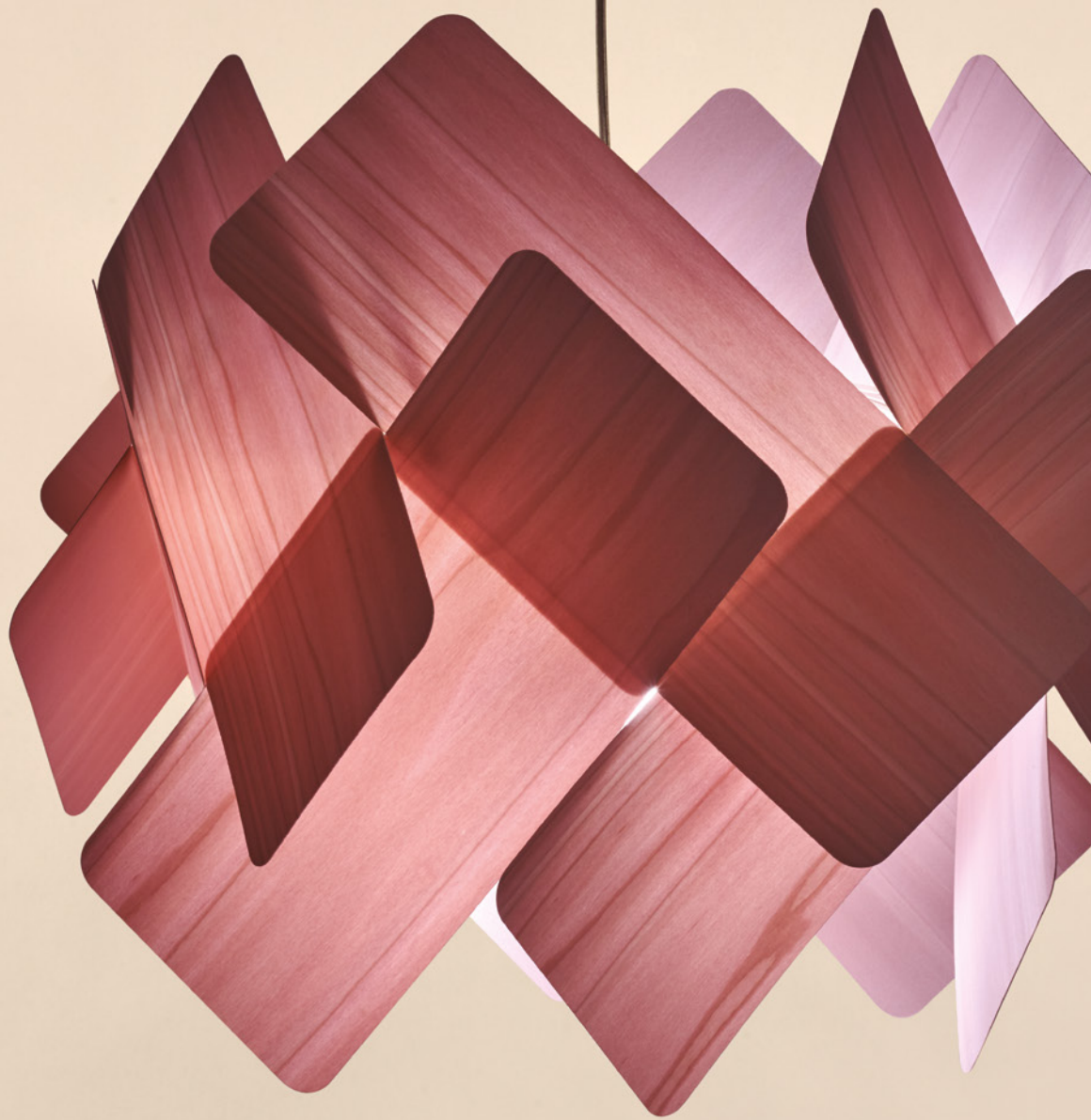

XIII.

“I’d like to rest,” I dared to say.

“Should I turn off the light?” she asked.

“No, it’s the light that relaxes me.”

—Me gustaría descansar —me atreví a decirle.

—¿Quiere que le apague la lámpara? —propuso.

—No, es la luz la que me descansa.





GEA

MARIVÍ CALVO

FAMILY

SUSPENSION / FLOOR / WALL & CEILING

TECHNICAL DATA

SEE PG. 542



COS PG-20 Villa El Nido. Architects: A-cero. Marbella, Spain.

COSMOS FLOOR

Ref. COS PG

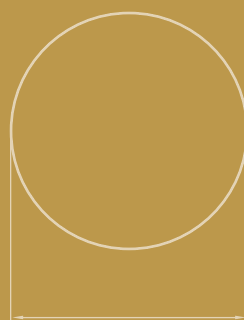
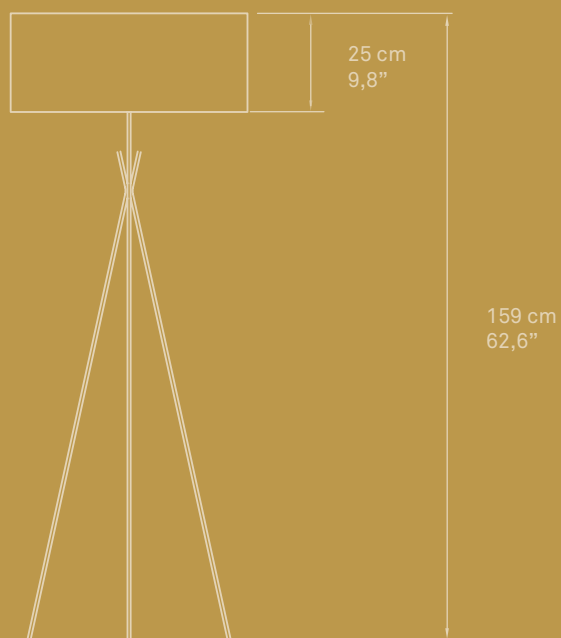

ø 60 cm
ø 23,6"



GEA S-20

GEA

SMALL SUSPENSION

Ref. GEA S

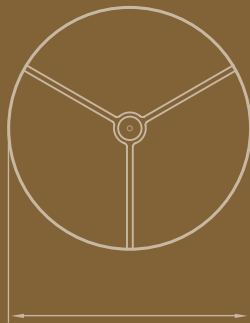
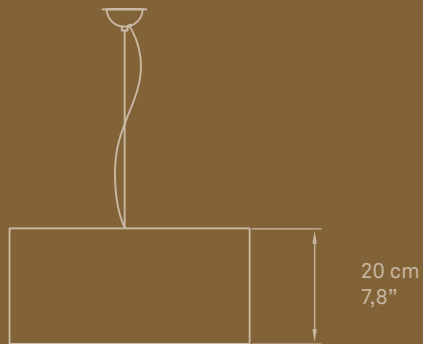

ø 42 cm
ø 16,5"



GEA S-24-26-30, SGEA S-24-28-29 Le Meridien Hotel. Tarragona, Spain.





GEA

LARGE SUSPENSION

Ref. SGEA S

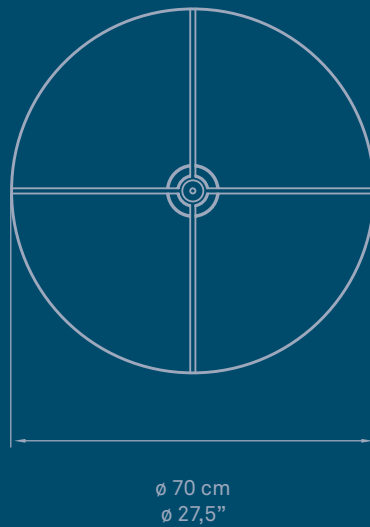
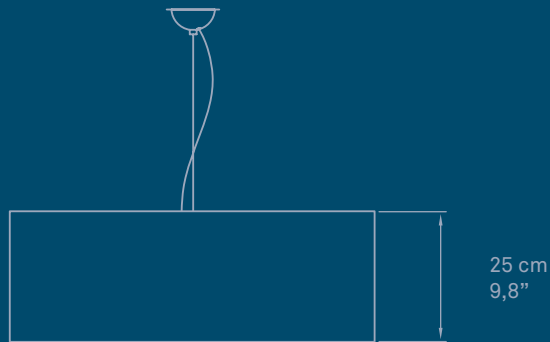



SGEA S-29 Le Meridien Hotel. Tarragona, Spain.





GEA

WALL & CEILING

Ref. G42 A LED

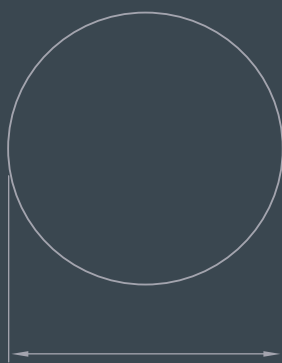

ø 42 cm
ø 16,5"



10 cm
3,9"

Ref. G30 A LED



ø 30 cm
ø 11,8"



10 cm
3,9"

Ref. G20 A LED



ø 20 cm
ø 7,9"



10 cm
3,9"



G20 A LED-29, G30 A LED-29, G42 A LED-29 Le Meridien Hotel, Tarragona, Spain.



XIV.

“What was the name of that game where you go from earth to heaven?”

“Hopscotch,” she answered with a gleam in her eyes.

—¿Cómo se llamaba aquel juego en el que ibas de la tierra al cielo?

—Rayuela —respondió, y se le iluminaron los ojos.



GUIJARROS

MARIVÍ CALVO

FAMILY

WALL & CEILING

TECHNICAL DATA

SEE PG. **544**



G6 A LED-21, G5 A LED-29, G2 A LED-24

GUIJARROS

WALL & CEILING

Ref. G6 A LED

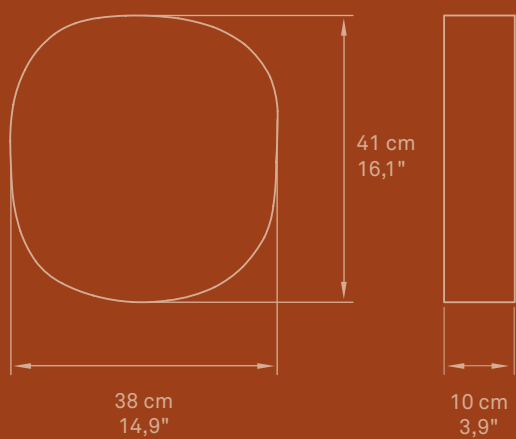

Ref. G2 A LED

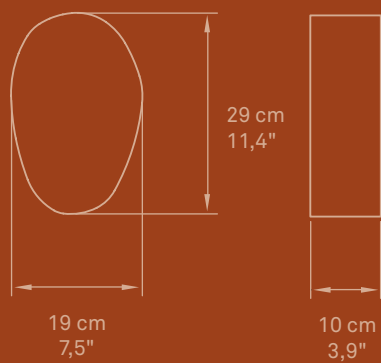

Ref. G5 A LED

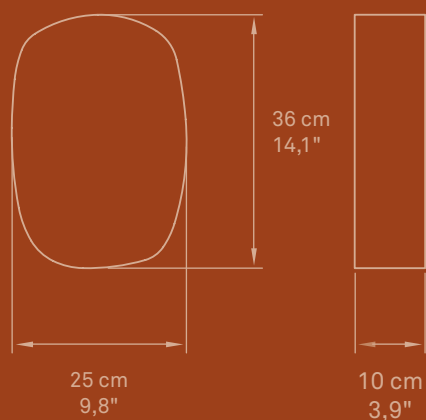



G6 A LED-24, G5 A LED-28, G5 A LED-26, G2 A LED-25



XV.

“Sometimes, it’s all so easy,” he said, as the boat distanced itself from the coast..

—A veces, resulta todo tan fácil —dijo, mientras el barco se alejaba de la costa.



HI-COLLAR

**RAY POWER
WALL**

TECHNICAL DATA
SEE PG. **545**



HICOLA LED-21 Palau de Casavells. Art, Antiques, Design, Architecture. Girona, Spain.

HI-COLLAR WALL

Ref. HICOL A LED

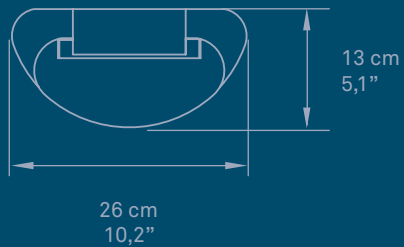
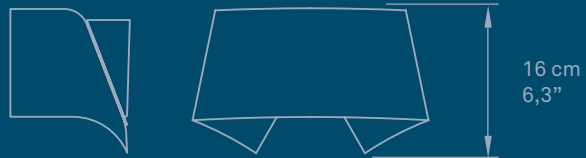



HICOLA LED-20 Le Meridien Hotel. Tarragona, Spain.





HICOL A-32 La Monella Jewelers. Valencia, Spain.



XVI.

“A straight line is the shortest distance between...”
“Two,” then I kissed you and didn’t finish the sentence
either.

—La línea recta es la distancia más corta entre...

—Dos —te besé, tampoco yo acabé la frase.





I CLUB

BURKHARD DÄMMER

FAMILY

SUSPENSION / WALL / CEILING / TABLE

TECHNICAL DATA

SEE PG. **545**



I-CLUB SLIM SUSPENSION

Ref. I SSL LED

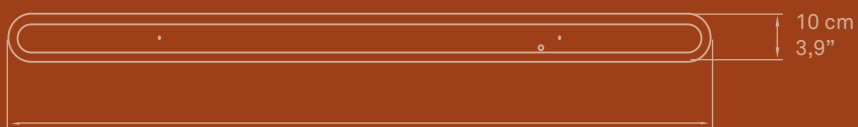
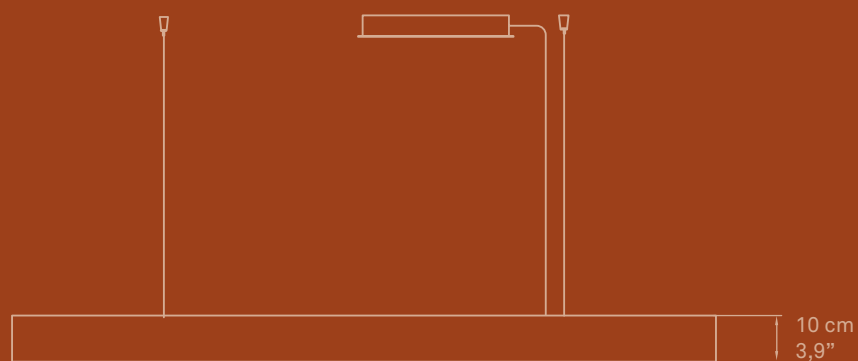

153 cm
60,2"



ISSLED-21 Palau de Casavells. Art, Antiques, Design, Architecture. Girona, Spain.





I-CLUB SLIM WALL

Ref. I ASL LED

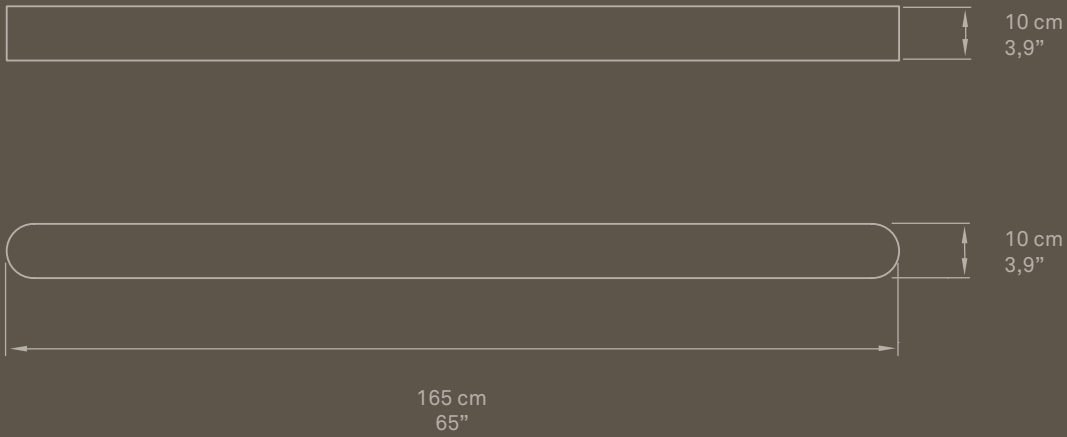



IASL LED-29 Le Meridien Hotel. Tarragona, Spain.



I ASL LED-29



IAG LED-25 Rabobank, Netherlands.

I-CLUB LARGE WALL & CEILING

Ref. I AG LED

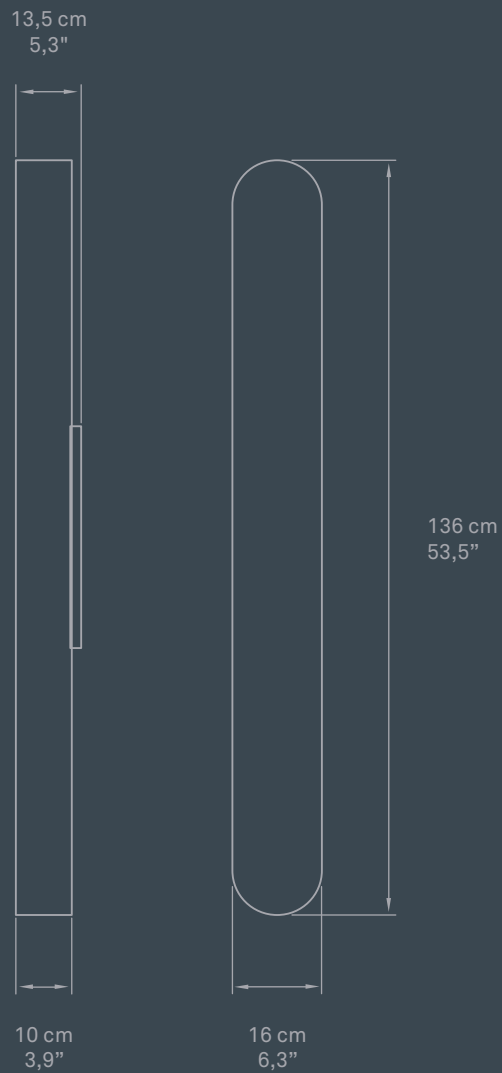



I-CLUB WALL

Ref. I A LED

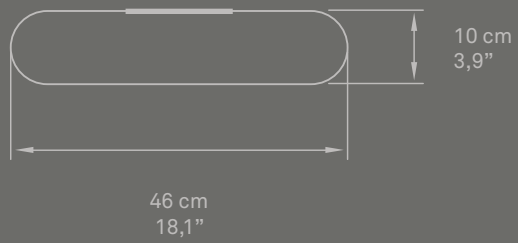
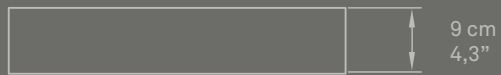



IA LED-21 Caro Hotel, Valencia, Spain.





I-CLUB TABLE

Ref. I M LED

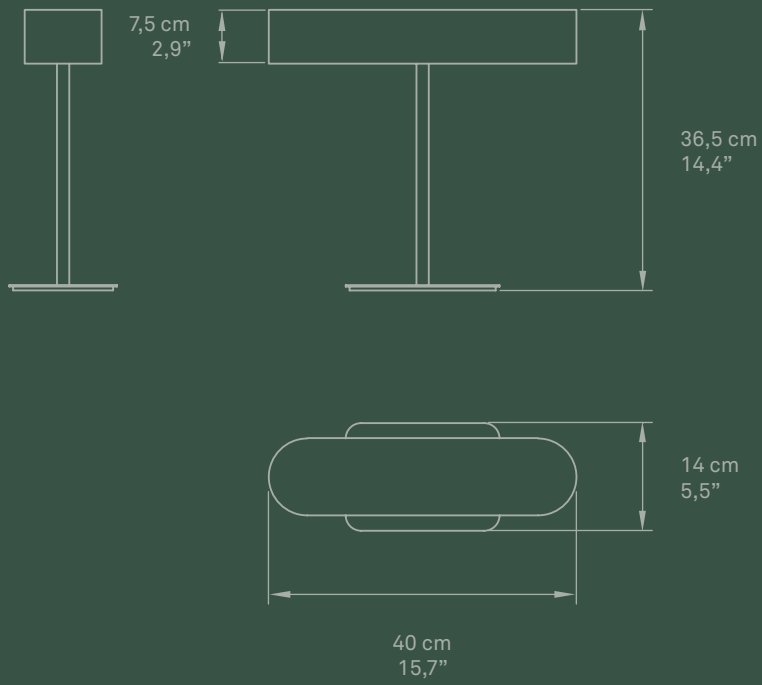





IM LED-21 Palau de Casavells. Art, Antiques, Design, Architecture. Girona, Spain.

XVII.

“I should start thinking about saying goodbye,” he said.

“Are you in a hurry?” she replied.

“Not anymore.”

—Debería empezar a despedirme.

—¿Tiene prisa?

—Ya no.



ICON

BURKHARD DÄMMER
SUSPENSION

TECHNICAL DATA
SEE PG. **547**



ICON S-28 Palau de Casavells. Art, Antiques, Design, Architecture. Girona, Spain.

ICON

SUSPENSION

Ref. ICON S

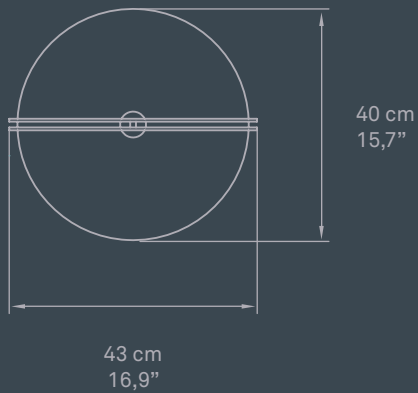
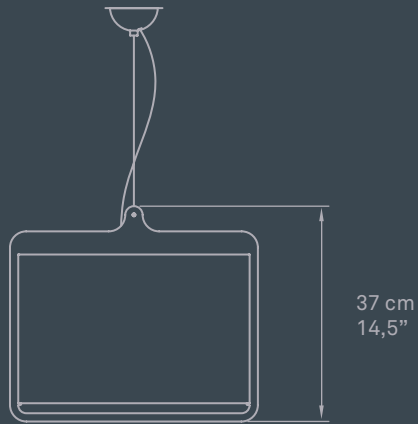



ICON S-20 Palau de Casavells. Art, Antiques, Design, Architecture. Girona, Spain.





XVIII.

“What if we were to travel around the world?”

“I’d love to. Where do we start?”

“From the beginning.”

—¿Y si diéramos la vuelta al mundo?

—Me encantaría. ¿Por dónde empezamos?

—Por el principio.



KIM

MARIVÍ CALVO
SUSPENSION

TECHNICAL DATA
SEE PG. **547**



KIM SG LED-22

KIM

LARGE SUSPENSION

Ref. KIM SG LED

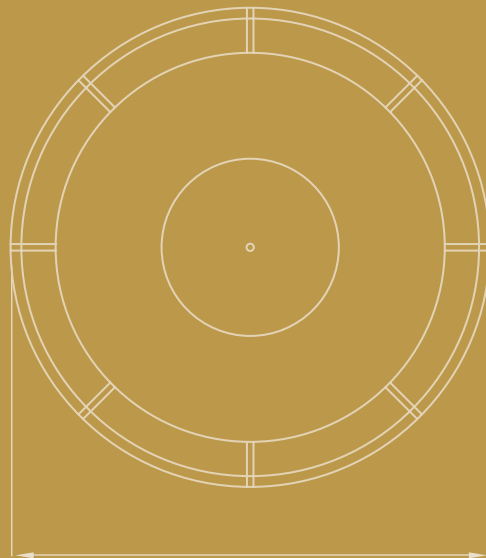
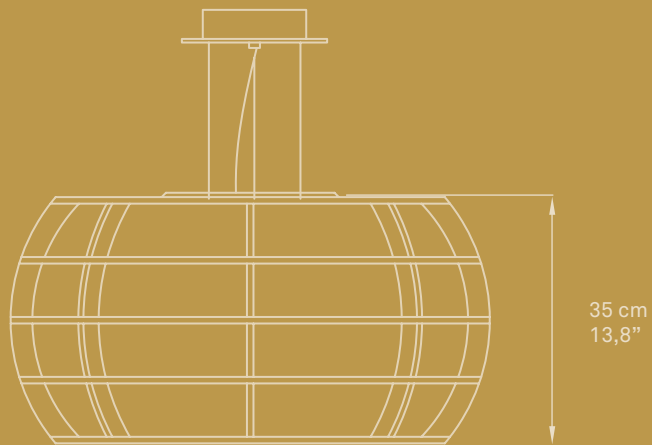



KIM

SMALL SUSPENSION

Ref. KIM SP LED

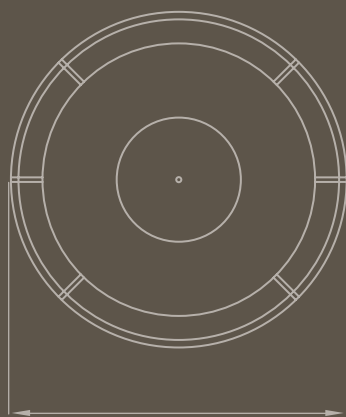
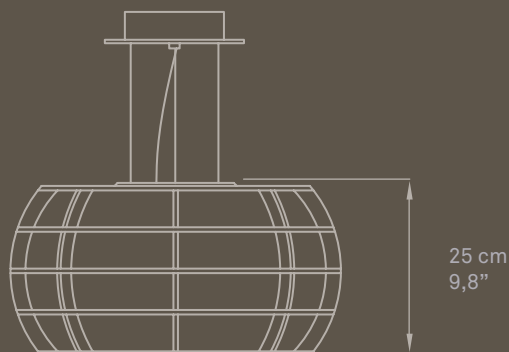



KIM SP LED-20







XIX.

“Is the impossible possible?” Margaret asked.
“I think so,” said James. “I am here.”

—¿Es posible lo imposible? —preguntó Margaret.
—Creo que sí —respondió James—, estoy aquí.

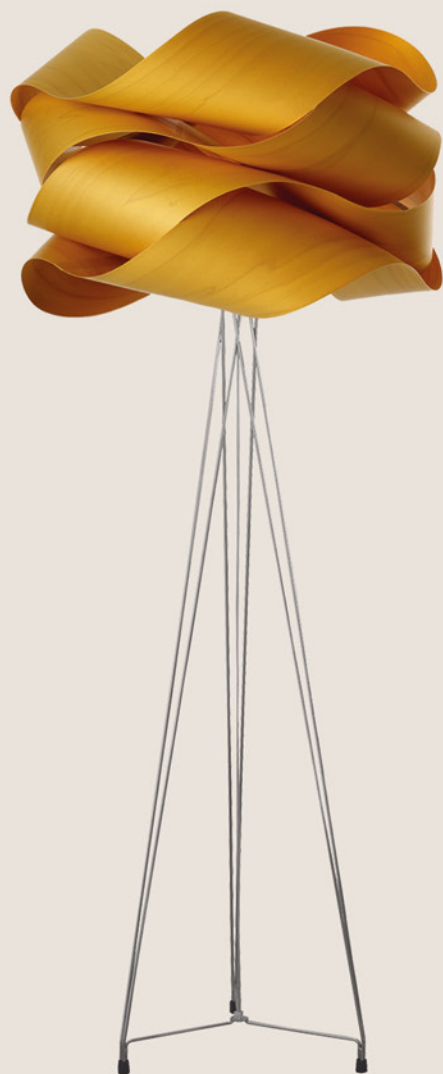



RAY POWER
FAMILY
SUSPENSION / FLOOR

TECHNICAL DATA
SEE PG. **548**



LK SP-21 Equestrian Club Residence. Interior Design: Krista Watterworth. Wellington, Florida. Photography: Jessica Klewicki Glynn.

LINK

SMALL SUSPENSION

Ref. LK SP

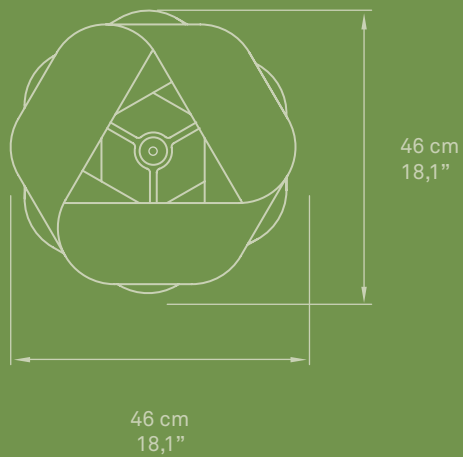
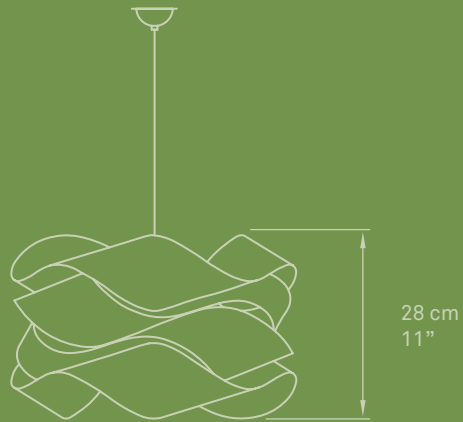



LK SG-22 President Street Residence, Interior Design: Common Bond Design, Photography: Biz Jones, Brooklyn

LINK

LARGE SUSPENSION

Ref. LK SG

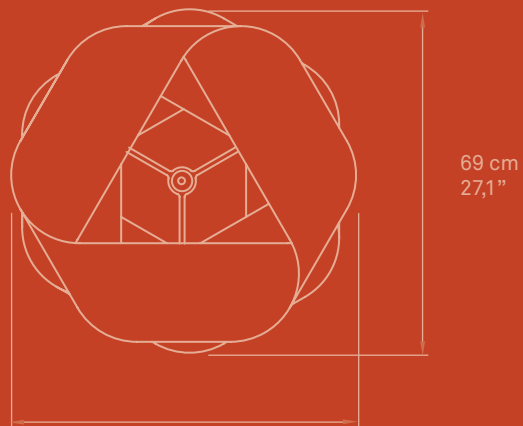
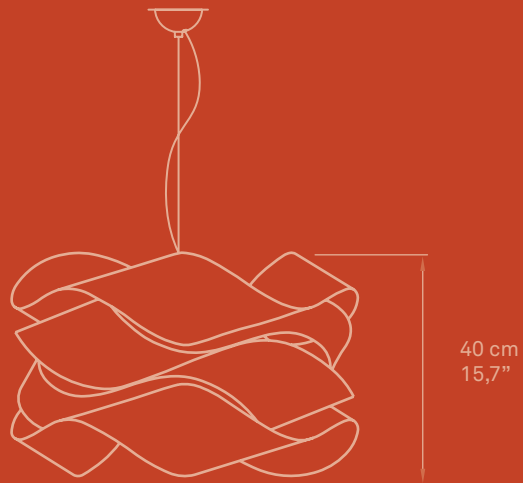

69 cm
27,1"



LK SG-21

Location:
France

Architects:
Catlin Stothers
Architects



LK SG-21 Bachelor Loft. Design: Stephane Chamard. Photographie my Lisa Petrole . Toronto, Canada.



LK SG-24

Location:
Pennsylvania

Architects:
Luca Construction
and Design, Inc



LK SG-21

Location:
Seattle

Architects:
Dave Dykstra
Architects

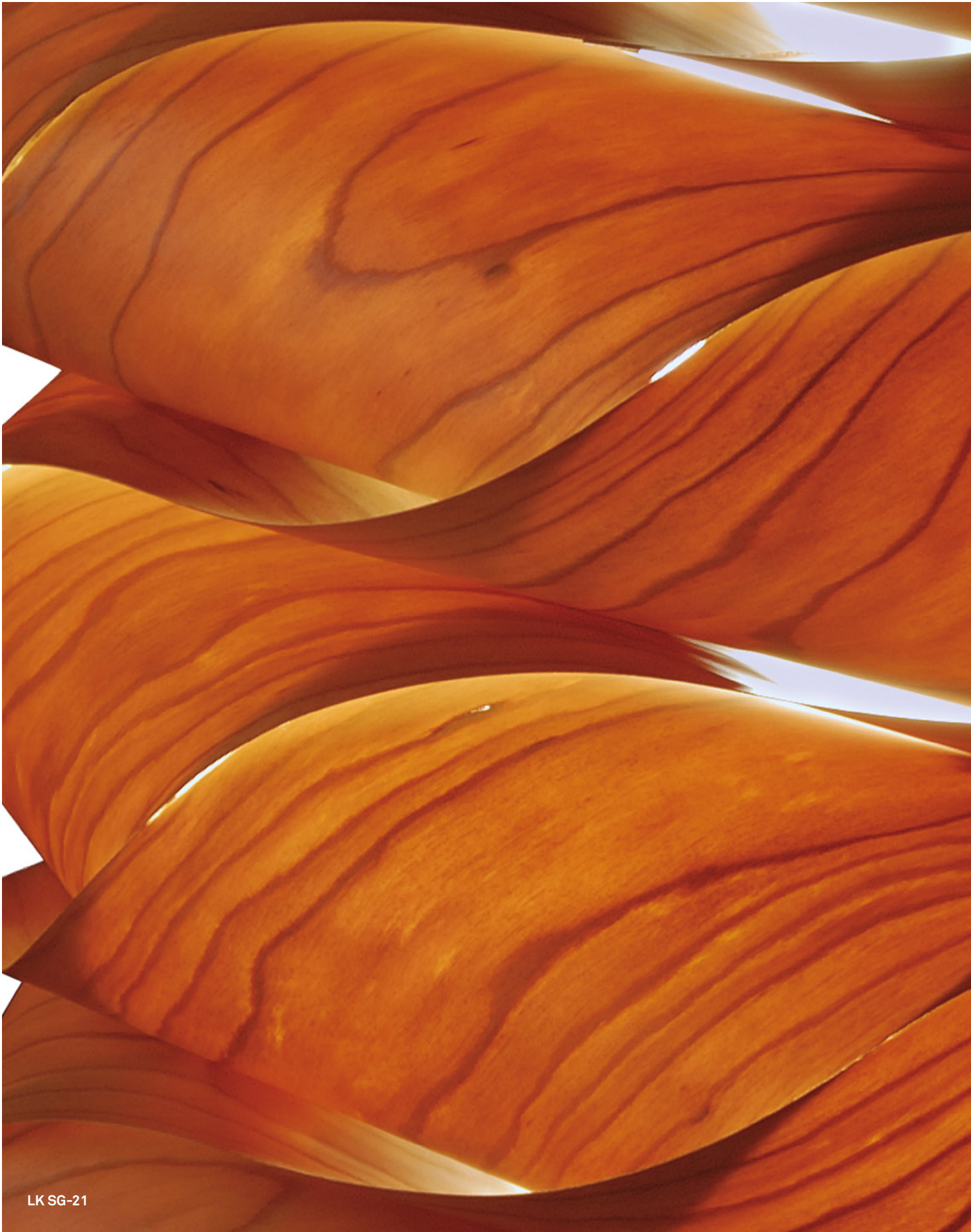

LK SG-21

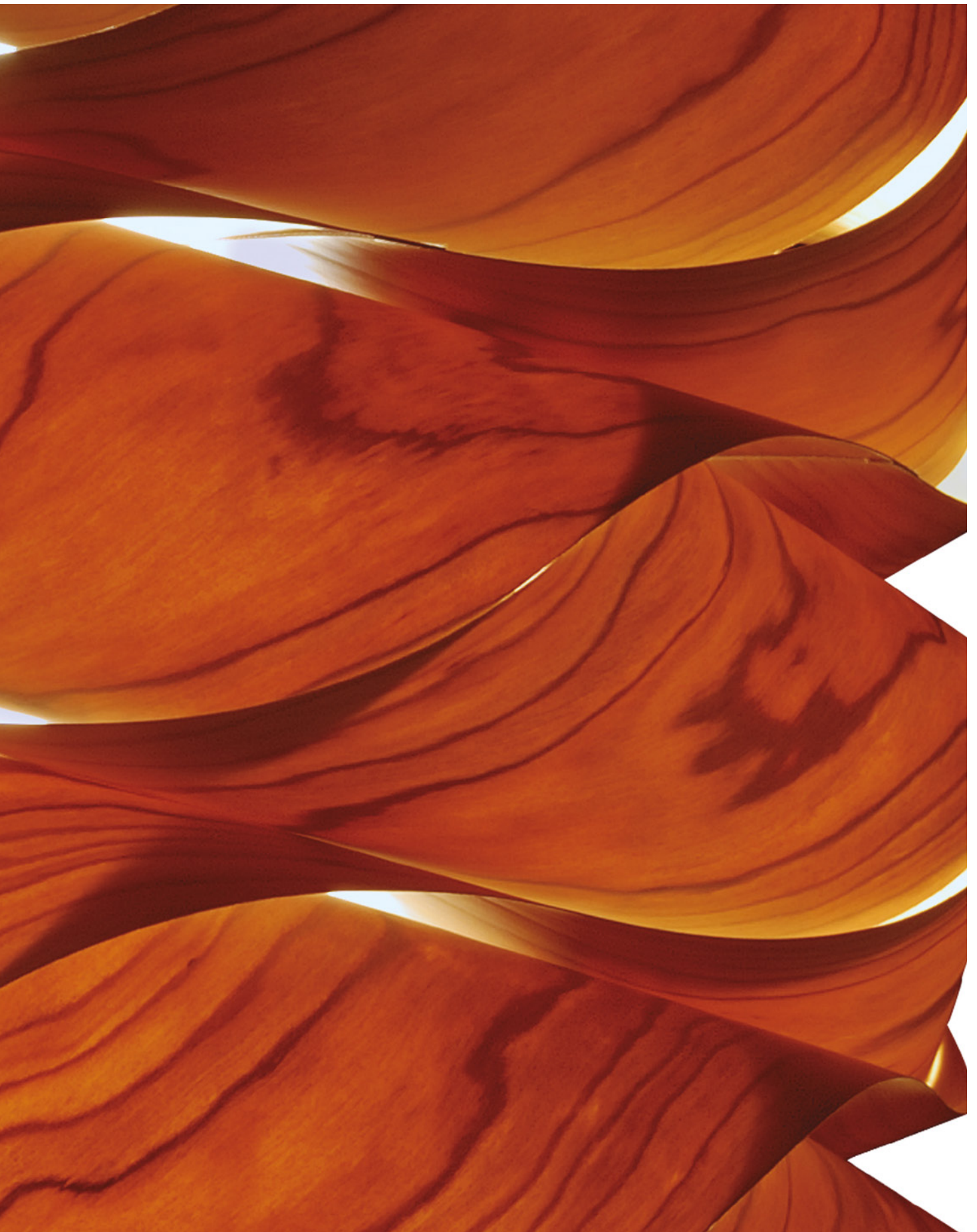



LINK FLOOR

Ref. LK P

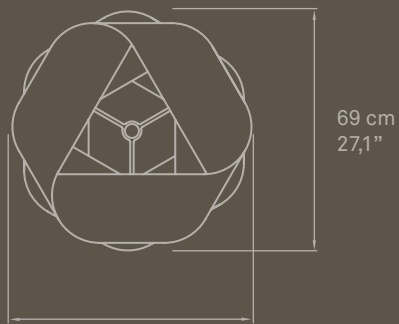
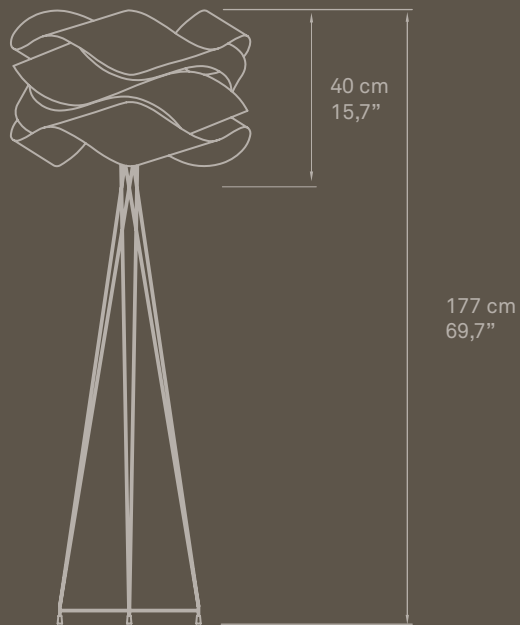

69 cm
27,1"



LKP-20



XX.

“We should rule out the idea that everything that grows, always grows upwards.”

“Hugs grow horizontally” I said, as I hailed a taxi.

—Debemos descartar la idea de que todo lo que crece, crece siempre hacia arriba.

—Los abrazos tienen crecimiento horizontal —respondí, mientras paraba un taxi.





LINK CHAIN

RAY POWER & MARIVÍ CALVO
SUSPENSION

TECHNICAL DATA
SEE PG. **549**



LK3 S-20 Petit Palace Savoy Alfonso XII Hotel, Madrid, Spain.

LINK CHAIN SUSPENSION

Ref. LK3 S



100 cm
39,4"

Ref. LK4 S

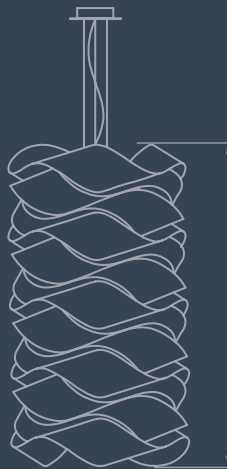

125 cm
49,2"

Ref. LK6 S



175 cm
69"

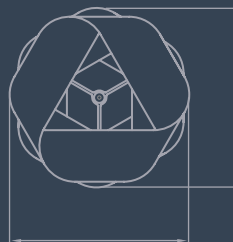

69 cm
27,1"

69 cm
27,1"



LK4 S-20







LK4 S, LK5 S, LK6 S-29 Element Hotel, Vancouver, Canada.



LINK MODULAR

SUSPENSION

Ref. LK MOD6 TOP
LK MOD1 EXT
LK MOD3 EXT
LK MOD4 EXT
LK MOD6 EXT

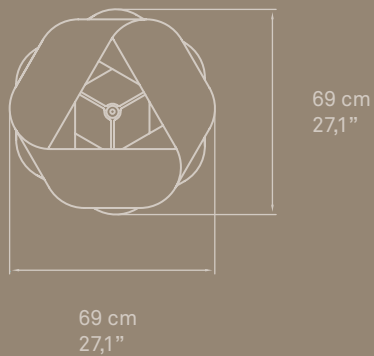
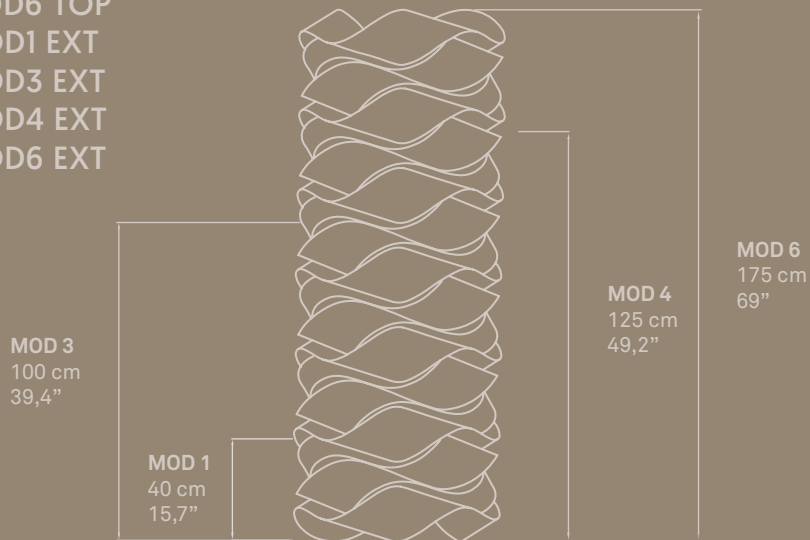



LK MOD6 BASE-20 + LKMOD1 EXT-20 HVB München Invest by Bottler & Lutz Architekten BDA.



XXI.

“Do you have any hobbies?” Mrs Jarret asked.
“I like to dance,” I responded without hesitating.
“You’ll be able to do that all day here.”

—¿Alguna afición? —preguntó Mrs Jarret.
—Me gusta bailar —no dudé la respuesta.
—Aquí podrá hacerlo todo el día.

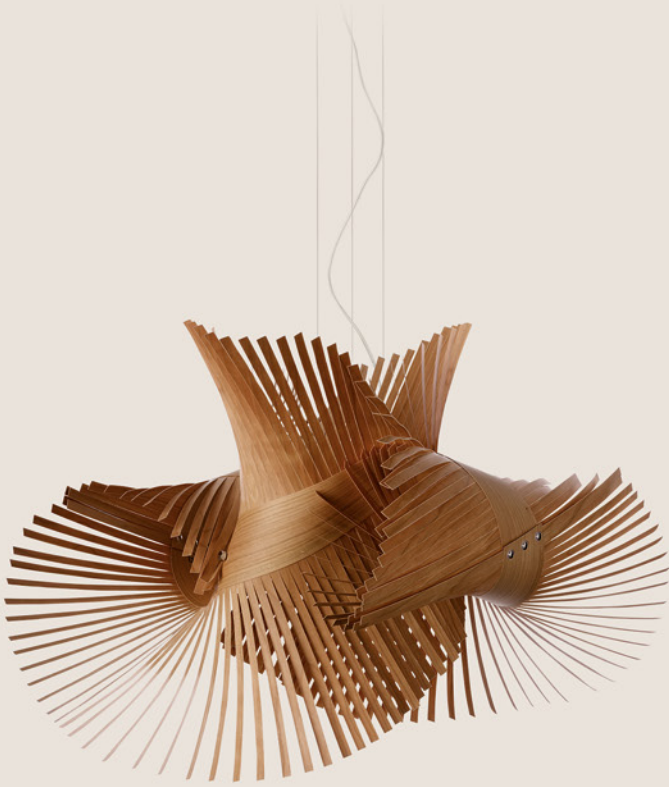

MINIMIKADO

MIGUEL HERRANZ
SUSPENSION

TECHNICAL DATA
SEE PG. **550**



MMIK S-29 Designed by Belén Ferrandiz. Madrid, Spain.

MINIMIKADO

SUSPENSION

Ref. MMIK S

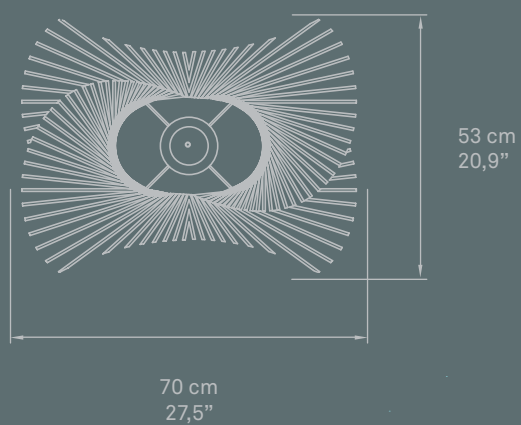
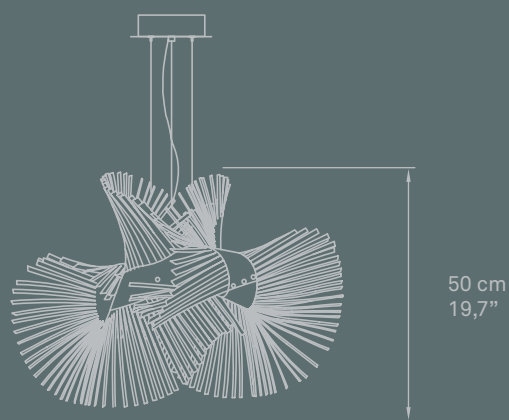



MMIK S-21 - Swananoah Residence, Dallas, Architect: David Stocker.



MMIK S-24 Villa El Nido. Architects: A-cero. Marbella, Spain.





XXII.

“Draw me a wave on the beach,” and I did.
“Now, draw me one on the sea.”

—Dibújame una ola sobre la playa —lo hice.

—Ahora, dibújame una sobre el mar.



NEW WAVE

**RAY POWER
SUSPENSION**

TECHNICAL DATA
SEE PG. **551**



NEW WAVE SUSPENSION

Ref. NWAV S LED

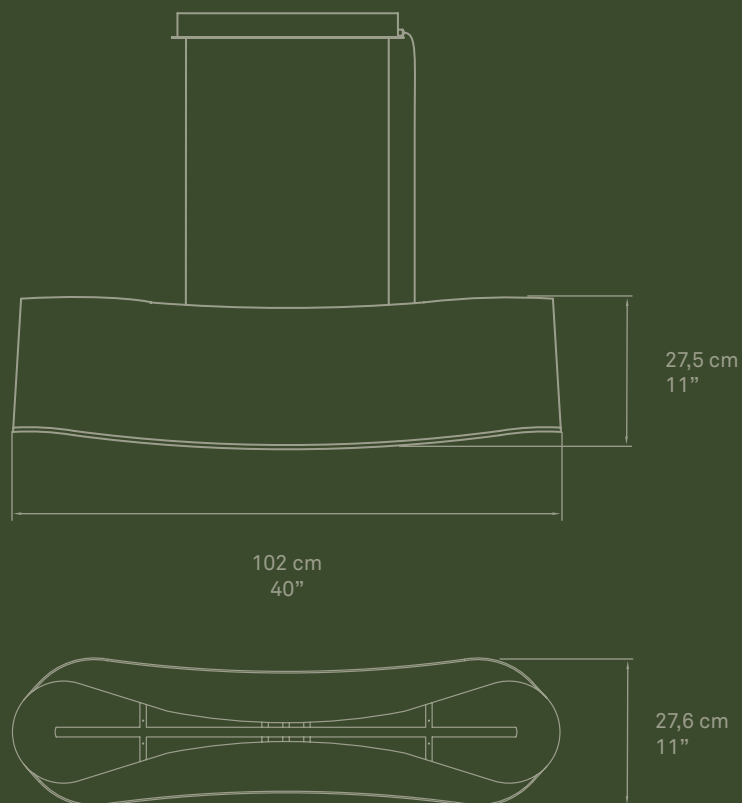



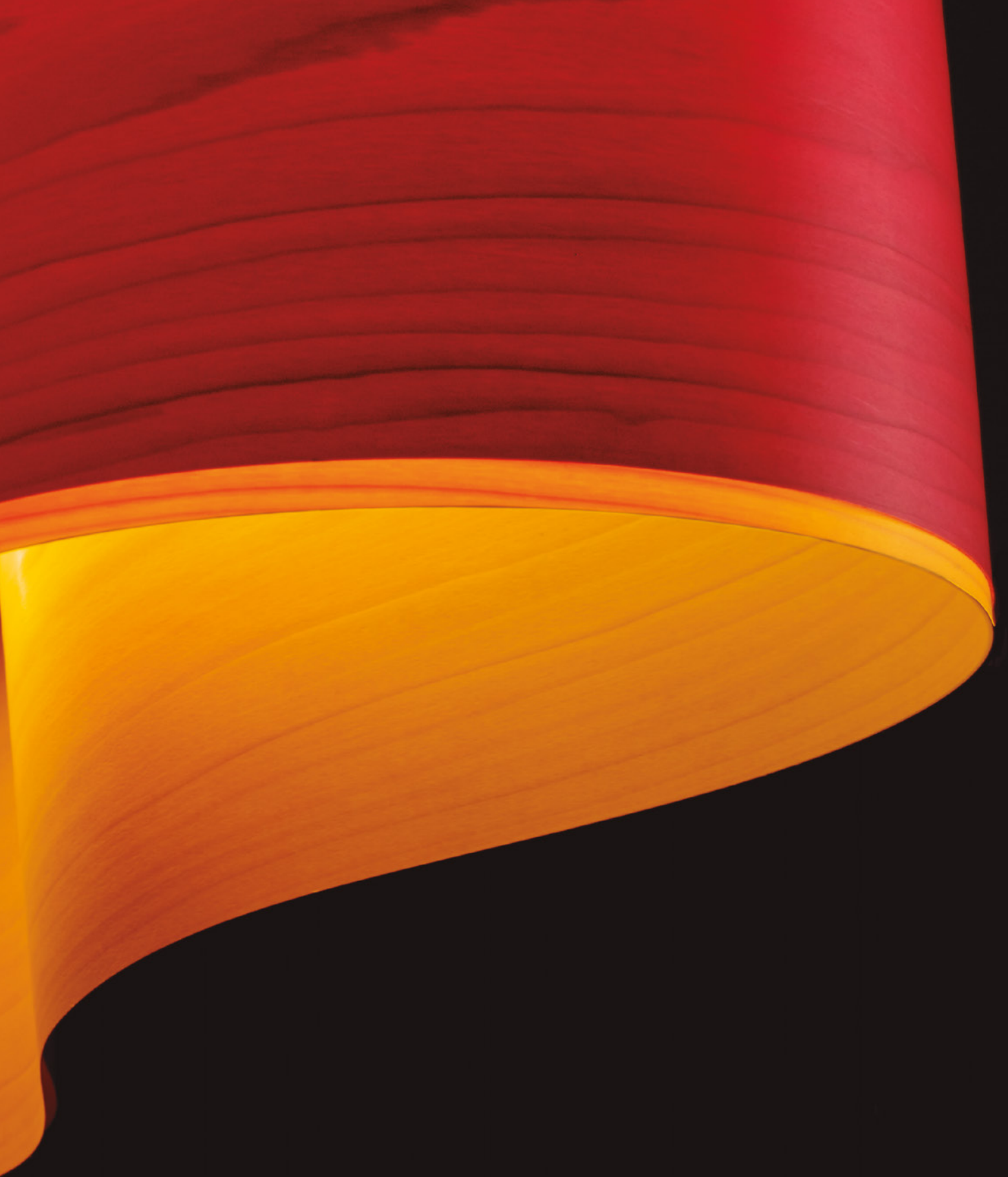



NWAV S LED-30/24 Palau de Casavells. Art, Antiques, Design, Architecture. Girona, Spain.







omung nicely.
KHEIR

XXIII.

“Put your hand on top of mine,” he asked. “They match.”

“Can I leave it there?” she replied.

“Yes, you can.”

—Ponga la mano encima de la mía —me pidió—, coinciden.

—¿Puedo dejarla ahí?

—Puede.



NUT

**RAY POWER
SUSPENSION**

TECHNICAL DATA
SEE PG. **551**



NUTS-20 Villa El Nido. Architects: A-cero. Marbella, Spain.

NUT SUSPENSION

Ref. NUT S

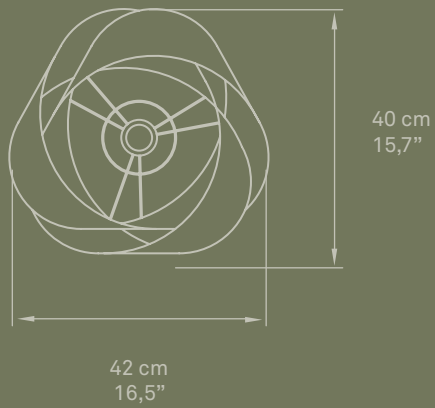
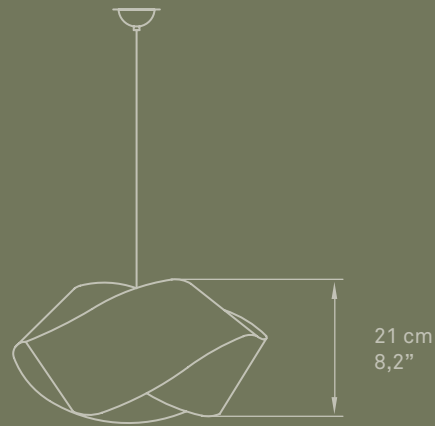



NUTS-26



NUTS-20 Palau de Casavells. Art, Antiques, Design, Architecture. Girona, Spain.

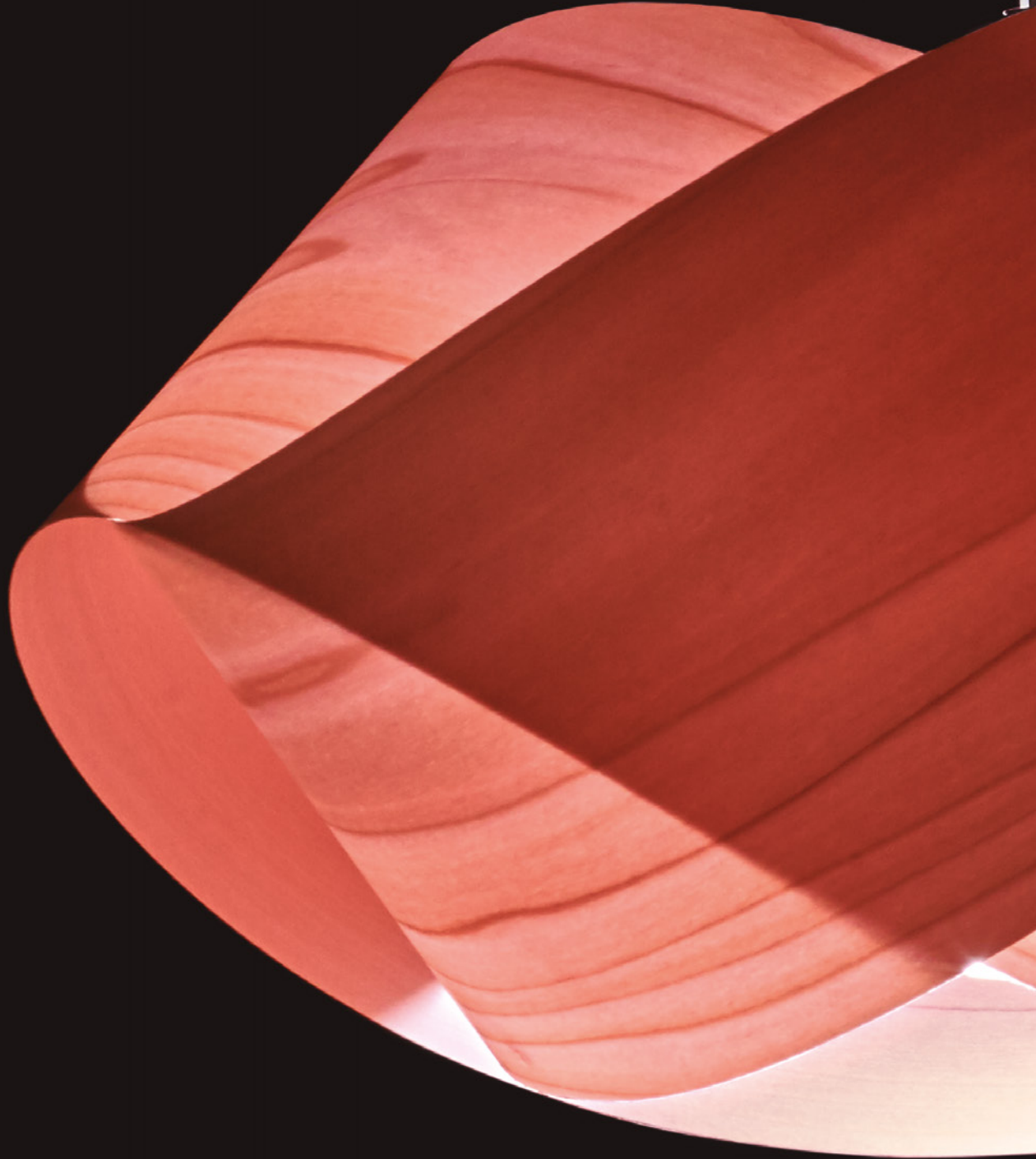

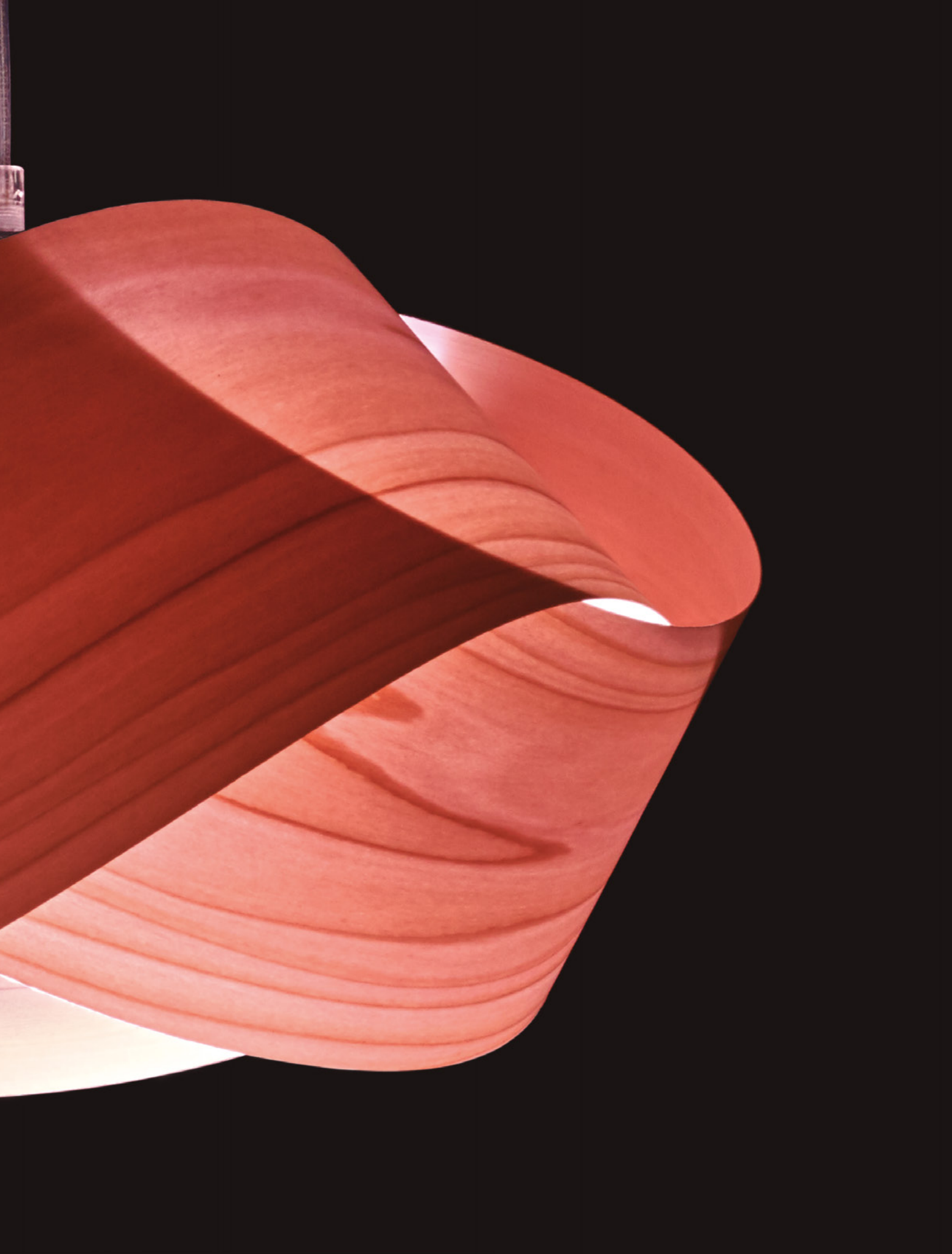

XXIV.

“Dear spectators, infinity is a state of being,” she concluded. The whole venue stood in applause.

“I’ll wait for you at the bar across the street Jacqueline,” I whispered quietly into her ear.

—Apreciado público, el infinito es un estado de ánimo —
concluyó. La sala entera se puso en pie para aplaudirle.

—Te espero en el bar de enfrente, Jacqueline —le susurré al oído.



ORBIT

MIGUEL HERRANZ
WALL

TECHNICAL DATA
SEE PG. **552**



ORB A-20 Caro Hotel, Valencia, Spain.

ORBIT WALL

Ref. ORB A

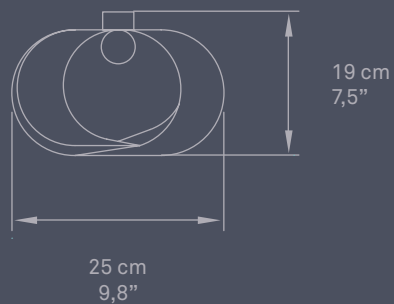
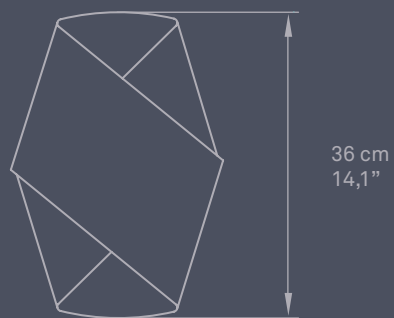



ORB A-20 Caro Hotel, Valencia, Spain.





ORB A-24 Matthew Hospital. Design: Portico Design Group. Photographie by Jason Brown. Columbia, Canada.



XXV.

“I’d like to see you again soon.” He said.

“Me too,” I replied. I stepped out into the garden for a moment then came back in.

“Are you always that fast?” he smiled.

—Me gustaría volver a verla pronto.

—A mí, también. Salgo un momento al jardín y regreso.

—¿Siempre es tan rápida?



PIKNIK

**MORATALLA, ORTÍN
& PLANELLS**
TABLE

TECHNICAL DATA
SEE PG. **552**



PKNK M LED-24

PIKNIK

TABLE

Ref. PKNK M LED
RECHARGEABLE LAMP

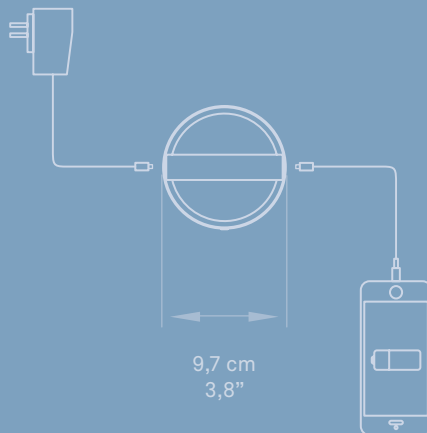
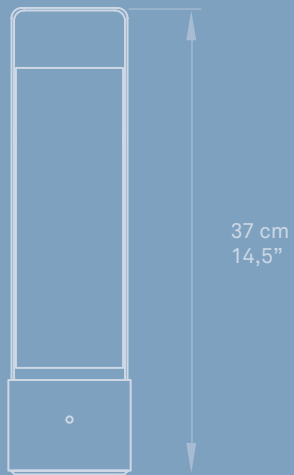





PKNK M LED-26

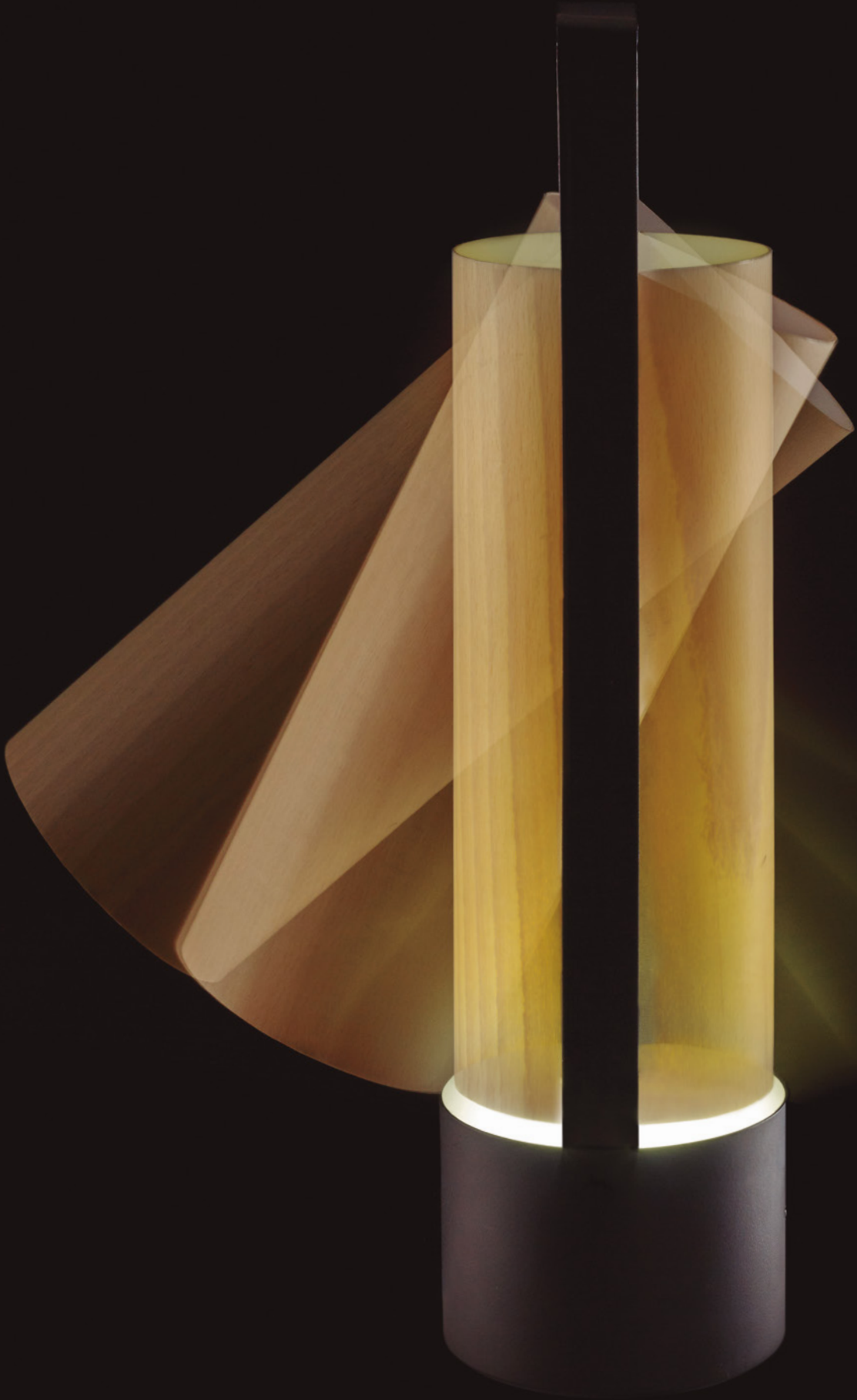

XXVI.

“A wall looks a lot like a map,” Bob said.

“Then choose a destination,” Margaret suggested.

—Una pared se parece mucho a un mapa —dijo Bob.

—Elige un destino —propuso Margaret.



PLEG
YONOH CREATIVE STUDIO
WALL

TECHNICAL DATA
SEE PG. **552**



PLEG WALL

Ref. PLEG A

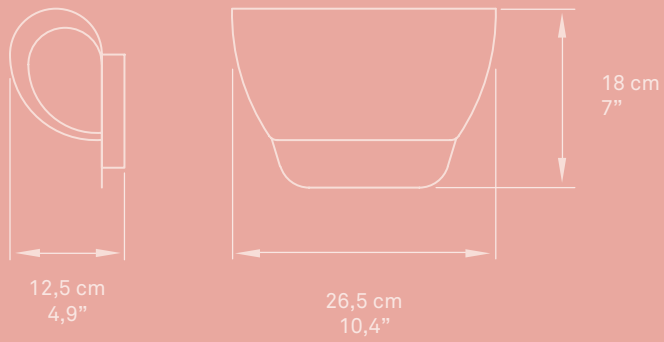



PLEG A-20 Caro Hotel, Valencia, Spain.





PLEG A-32



XXVII.

“Mary, draw a cloud for me please.”

“What do you want it to look like?”

“Like another cloud.”

—Mary, dibújame una nube, por favor.

—¿A qué quieres que se parezca?

—A otra nube.





POD / POPPY

BURKHARD DÄMMER

FAMILY
SUSPENSION

TECHNICAL DATA
SEE PG. **553**



POD SM-28 Palau de Casavells. Art, Antiques, Design, Architecture. Girona, Spain.

POD

MEDIUM SUSPENSION

Ref. POD SM

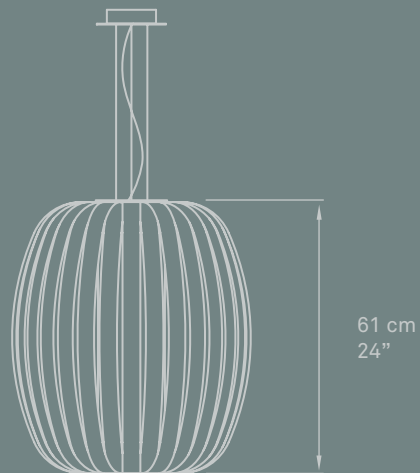



POPPY

SMALL SUSPENSION

Ref. POPY SP

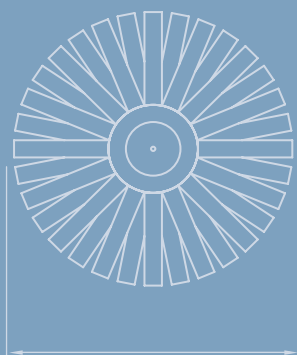
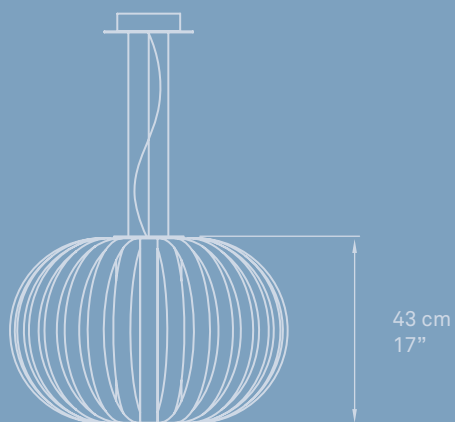

ø 63 cm
ø 24,8"



POPPY

MEDIUM SUSPENSION

Ref. POPY SM

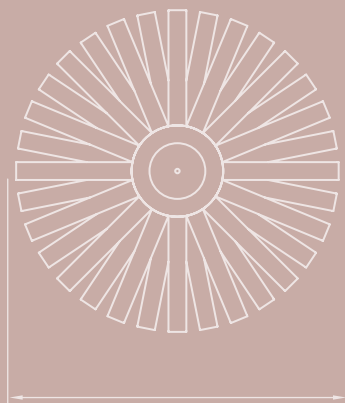



POPY SG-24, POPY SM-24, POD SM-24 Mandarin Oriental bar. Turkey.



XXVIII.

“Mama misses rainy days,” Luca wrote in his email.
“Tell her I think about her often,” I assured, knowing
that it wasn’t enough.

—Mamá echa de menos los días de lluvia —escribió Luca en su
mail.

—Dile que me acuerdo mucho de ella —aseguré, sabiendo que no
era suficiente.



RAINDROP

JAVIER HERRERO STUDIO

FAMILY
SUSPENSION

TECHNICAL DATA
SEE PG. **554**



RAINDROP SUSPENSION

Ref. RDROP SM



Ref. RDROP SP



ø 22 cm
ø 8,7"



ø 18 cm
ø 7"



RDROP SP & SM-20 Villa El Nido. Architects: A-cero. Marbella, Spain.





XXIX.

“I remember the day we met,” Malcolm said.
“I remember you drew a picture on a page in my
agenda.”

—Recuerdo el día que nos conocimos —dijo Malcolm.
—Yo recuerdo que hiciste un dibujito sobre la página de mi
agenda.





ROMANICA

MARIVÍ CALVO

FAMILY

SUSPENSION / WALL

TECHNICAL DATA

SEE PG. **555**



ROM50 S-24 Le Meridien Hotel. Tarragona, Spain.

ROMANICA

SUSPENSION

Ref. ROM30 S
Ref. ROM50 S

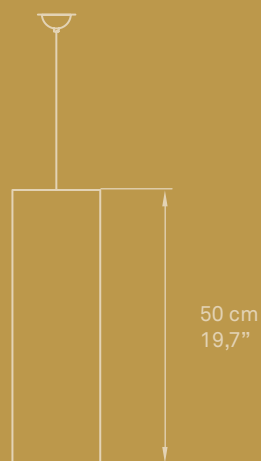
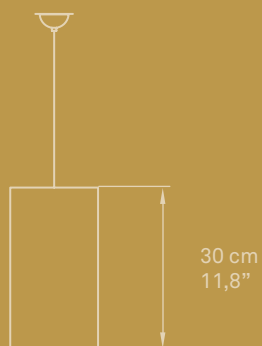



ROM120 S-22

ROMANICA SUSPENSION

Ref. ROM120 S

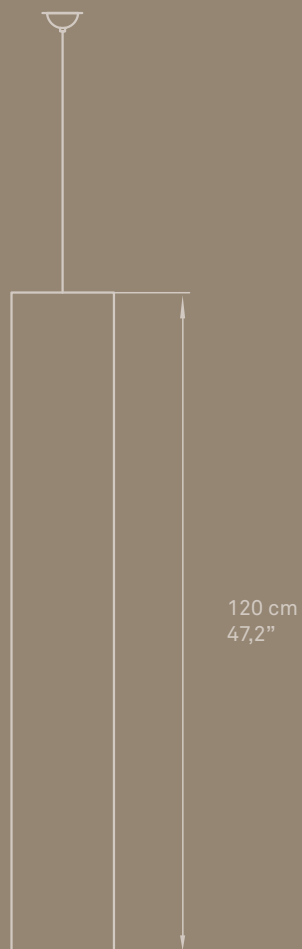



ROM120 S-21 Le Meridien Hotel, Tarragona, Spain.



028





ROM30 A-28, ROM50 A-28 Le Meridien Hotel. Tarragona. Spain.

ROMANICA

WALL

Ref. ROM30 A
Ref. ROM50 A

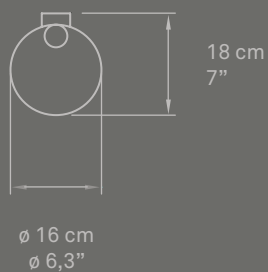
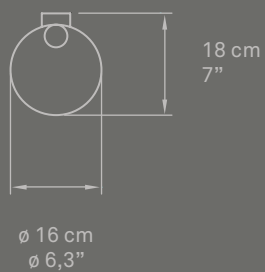
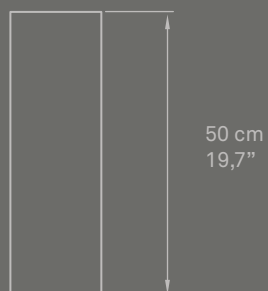
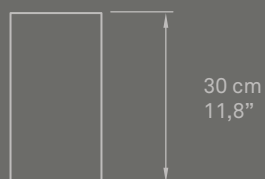

XXX.

“You assured me it was a star.”

“It’s a planet,” I answered. “it has perfect balance.”

—Es una estrella —aseguraste.

—Es un planeta —te respondí—, tiene el equilibrio perfecto.

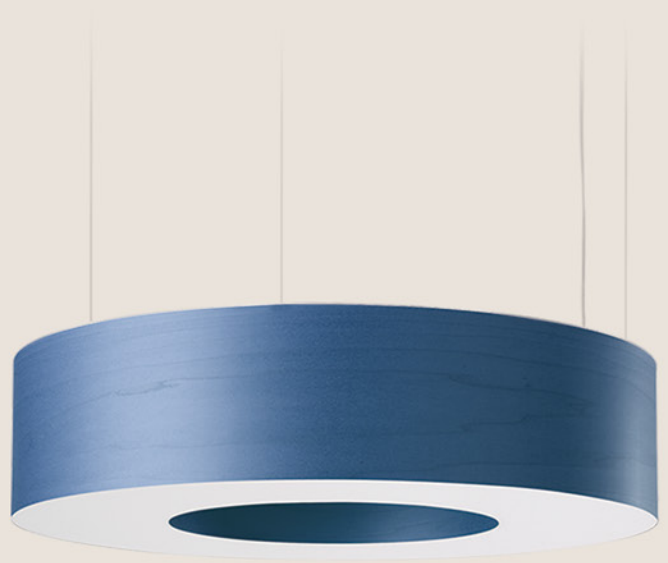



SATURNIA

OSKAR CEREZO

FAMILY

SUSPENSION

TECHNICAL DATA

SEE PG. **557**



SAT SP LED-21

SATURNIA

SMALL SUSPENSION

Ref. SAT SP LED

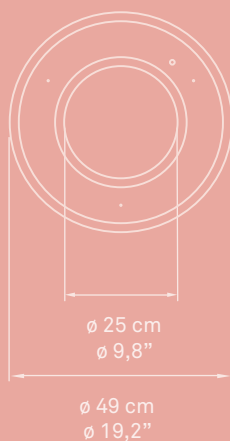
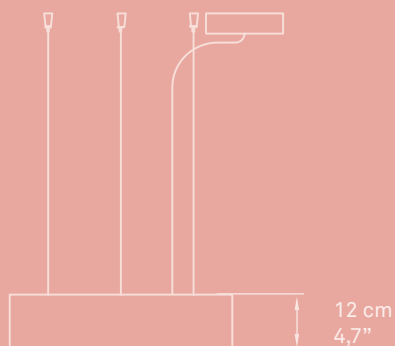



SAT SM LED-24 Villa El Nido. Architects: A-cero. Marbella, Spain.

SATURNIA

MEDIUM SUSPENSION

Ref. SAT SM LED

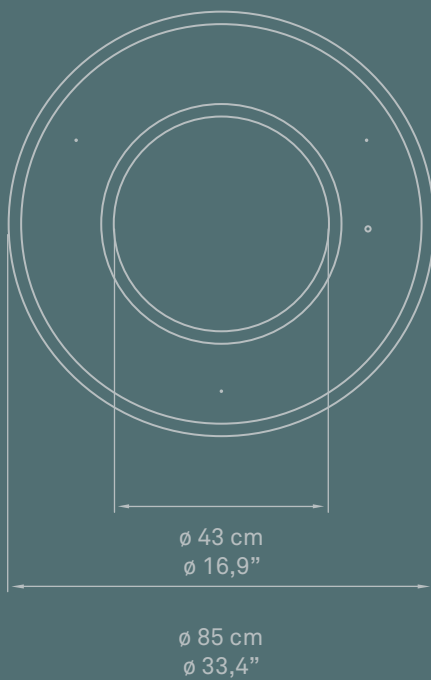
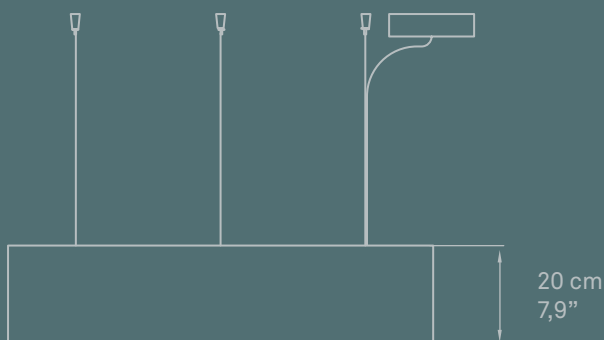

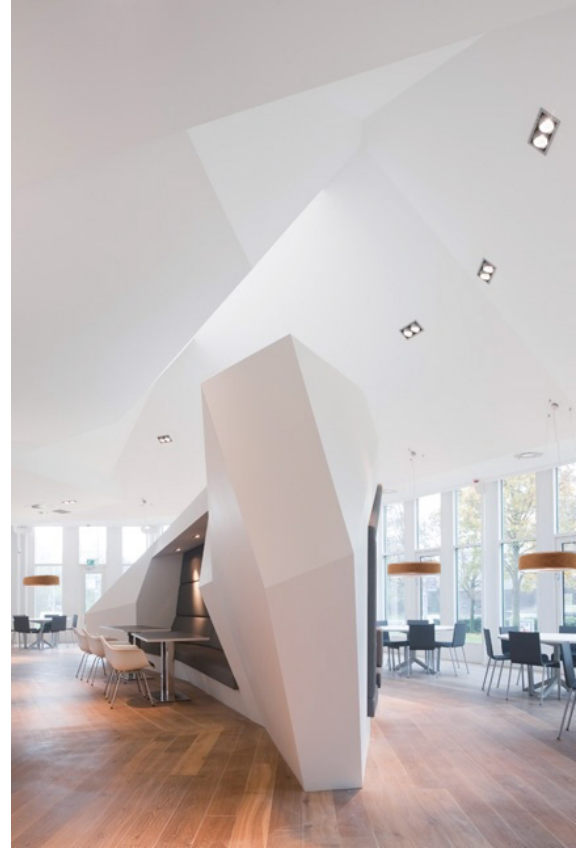

SAT SM LED-21

Project:
BNP Paribas
Investment Partners

Location:
Amsterdam

Architects:
Fokkema and
Partners
Architecten



SAT SM LED-21

Project:
Achmea Project

Location:
Netherlands

Architects:
Achmea
Verzekeringen,
Apeldoorn



SAT SM LED-24





SAT SG LED-30 Boardroom, private company, Netherlands.

SATURNIA

LARGE SUSPENSION

Ref. SAT SG LED

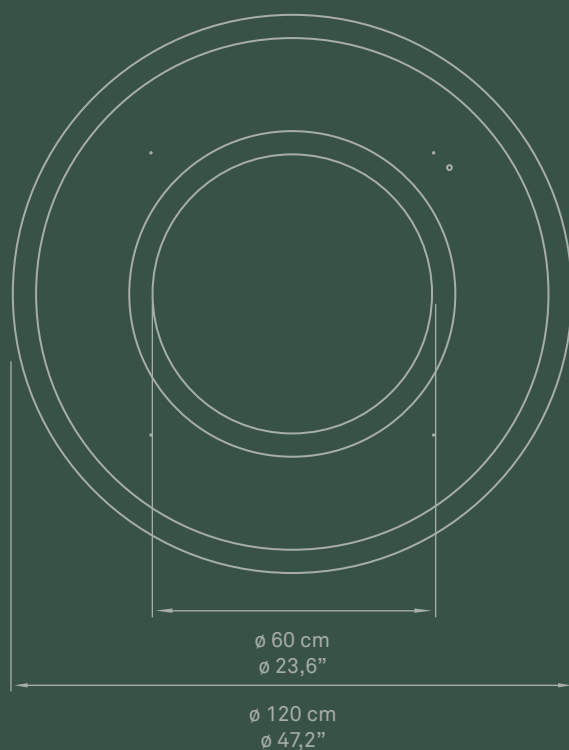
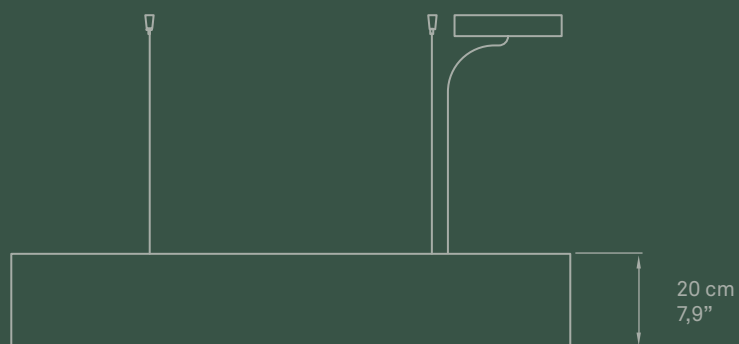

XXXI.

“What does a shadow weigh?” He was so provocative.
“Exactly the same as a silence.”

—¿Cuánto pesa una sombra? —era un provocador.
—Exactamente lo mismo que un silencio.



PAISLEY SCREEN

LUIS ESLAVA STUDIO
SCREEN

TECHNICAL DATA
SEE PG. **558**



PSLY SCR-21 Frame: Cherry

PAISLEY SCREEN

Ref. PSLY SCR





PSLY-SCR-21 | Frame: Cherry





PSLY SCR-21 Frame: Cherry



XXXII.

“Look me in the eye,” he asked.

“I can’t, you won’t stop moving,” I replied a little annoyed.

“It’s easy, just follow me.”

—Míreme a los ojos —me pidió.

—No puedo, no deja de moverse —respondí algo molesto.

—Es fácil: sígame.



SPIRO

REMEDIOS SIMÓN

FAMILY

SUSPENSION

TECHNICAL DATA

SEE PG. **558**



SPRO SG BK LED-29 Palau de Casavells. Art, Antiques, Design, Architecture. Girona, Spain.

SPIRO

LARGE SUSPENSION

Ref. SPRO SG LED

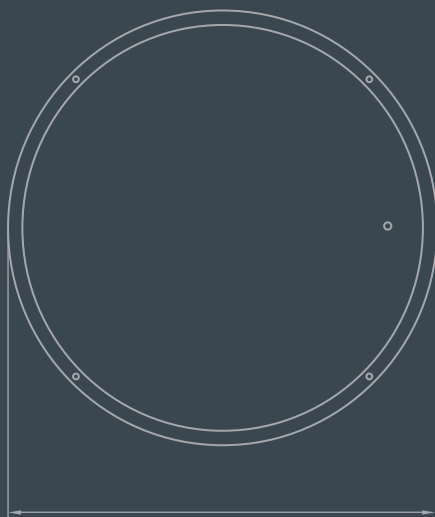
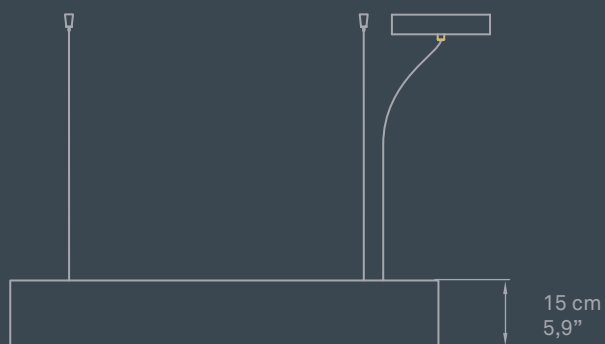

ø 96 cm
ø 37,8"



SPRO SG BK LED-21 Villa El Nido. Architects: A-cero. Marbella, Spain.





SPRO SM W LED-29 La Monella Jewelers. Valencia, Spain.

SPIRO

MEDIUM SUSPENSION

Ref. SPRO SM LED

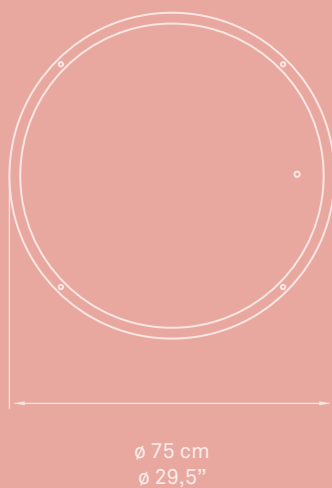
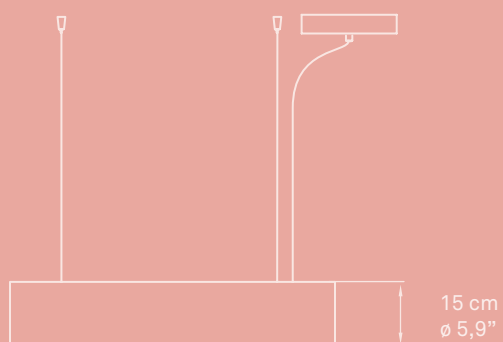



SPRO SM BK LED-29



XXXIII.

“I urgently need the definition of elegance,” Scarlett said, capriciously.

“Elegance is decision,” I replied, and continued to pack my folded shirts into my suitcase.

—Necesito urgentemente una definición de elegancia —pidió Scarlett, caprichosa.

—Elegancia es decidir—respondí, y seguí acomodando mis camisas plegadas en la maleta.

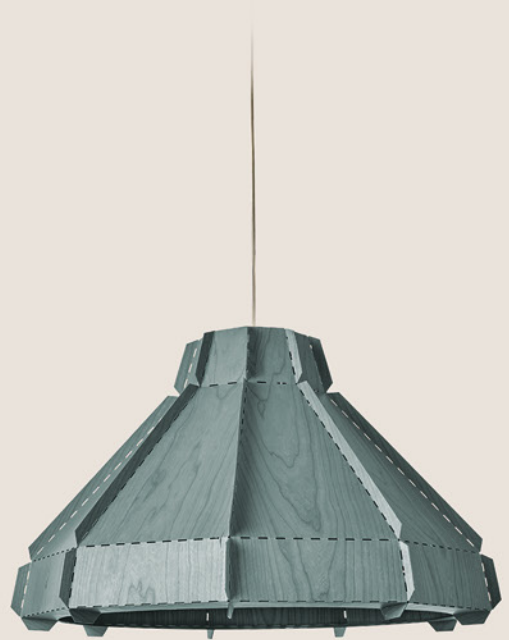



STITCHES

BUROJET
FAMILY
SUSPENSION

TECHNICAL DATA
SEE PG. **560**



STCH S BMK-20 Le Meridien Hotel. Tarragona, Spain.

STITCHES / BAMAKO

SUSPENSION

Ref. STCH S BMK

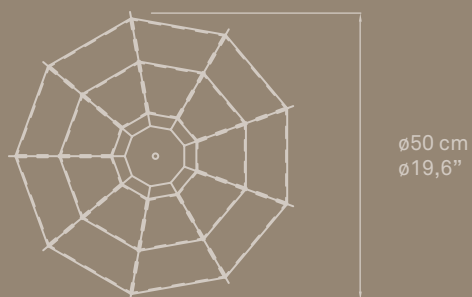
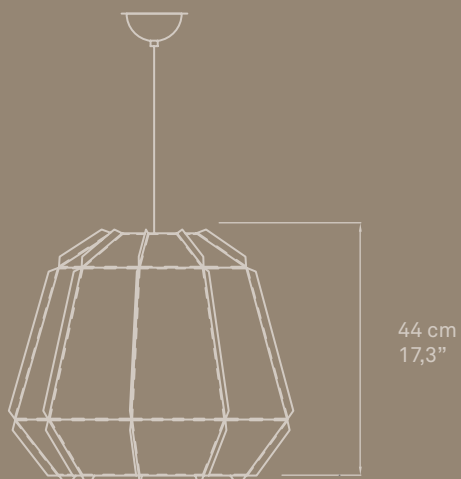



STITCHES / DJENNÉ

SUSPENSION

Ref. STCH S DJN

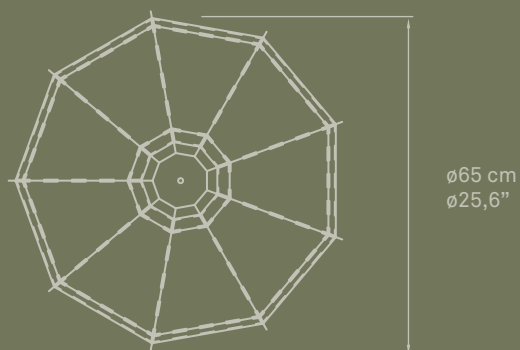
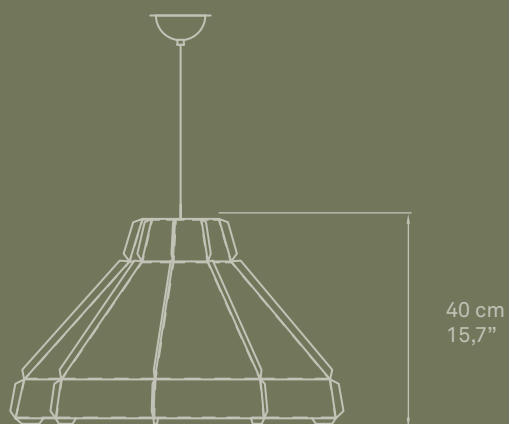



STCH S MOP-21 Patau de Casavells. Art, Antiques, Design, Architecture. Girona, Spain.

STITCHES / MOPTI

SUSPENSION

Ref. STCH S MOP

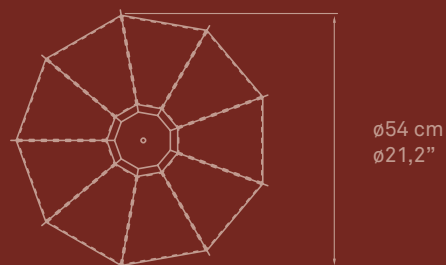
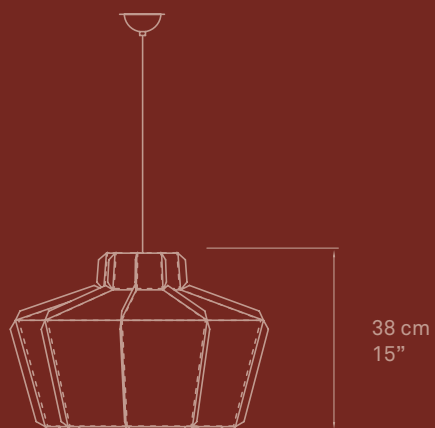

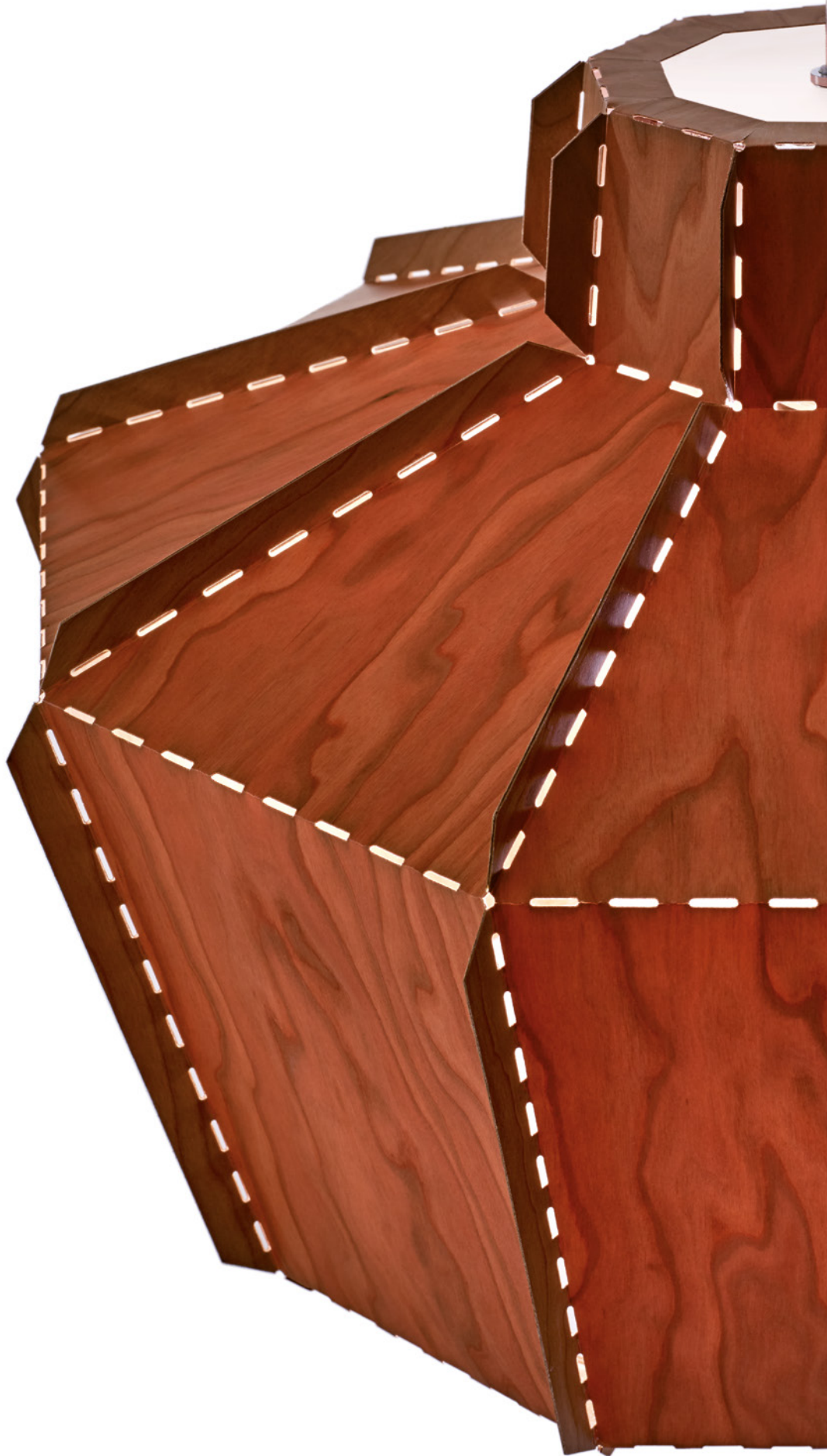

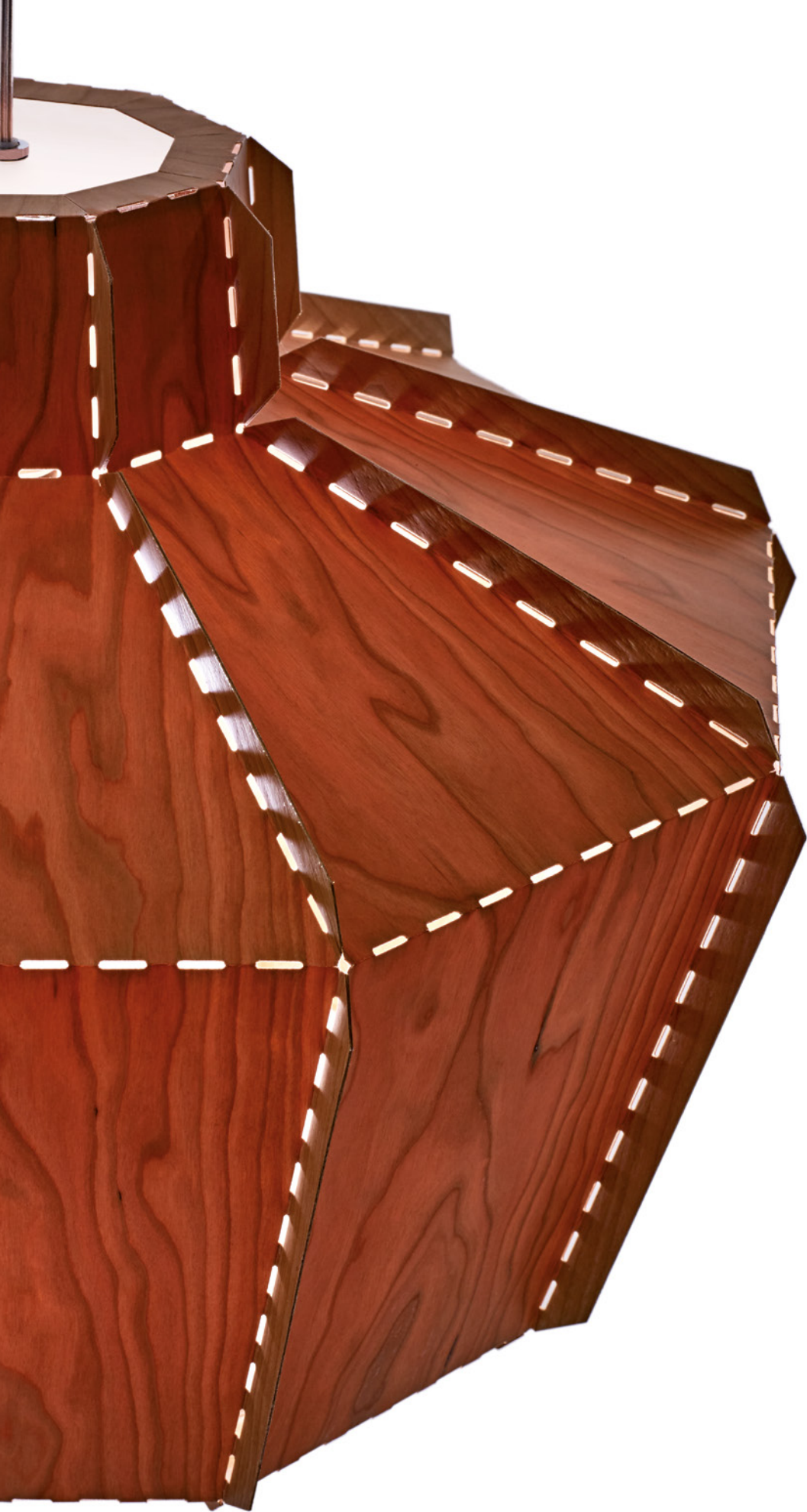



STCH S TBTU-21 Palau de Casavells. Art, Antiques, Design, Architecture. Girona, Spain.

STITCHES / TOMBUCTÚ

SUSPENSION

Ref. STCH S TBTU

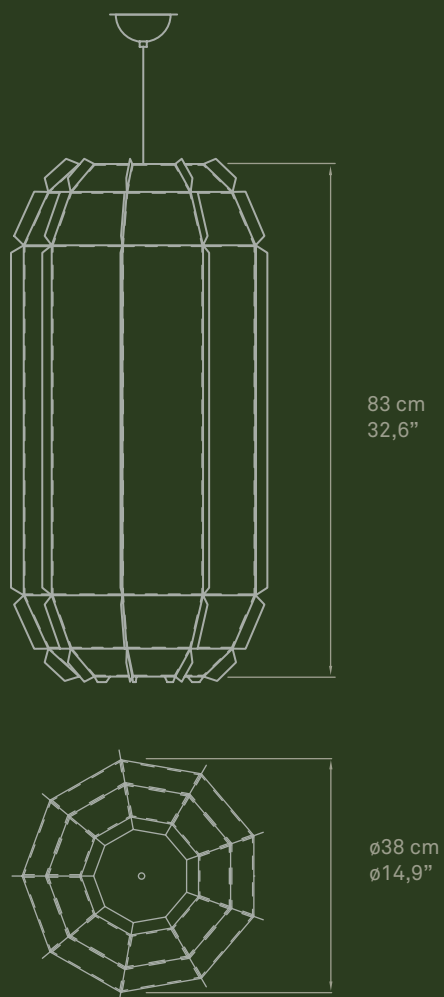



STCH SBTU-20 Le Meridien Hotel. Tarragona, Spain.



XXXIV.

“How did you get here?”

“The wind brought me.”

—¿Cómo ha llegado hasta aquí?

—Me ha traído el viento

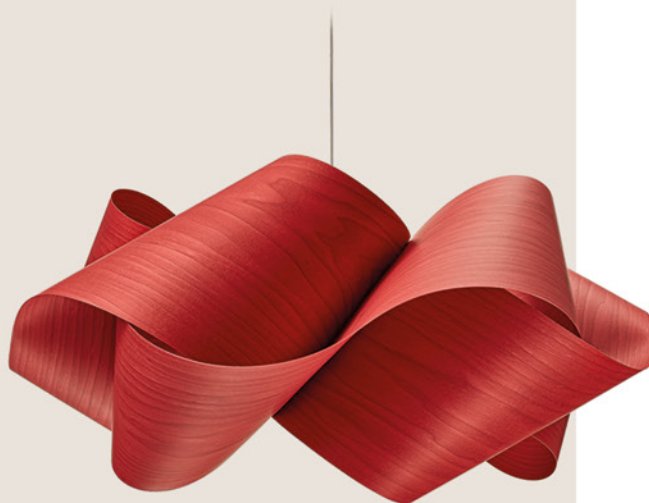

SWIRL

RAY POWER

FAMILY

SUSPENSION

TECHNICAL DATA

SEE PG. **561**



SWIRL

SMALL SUSPENSION

Ref. SWRL SP

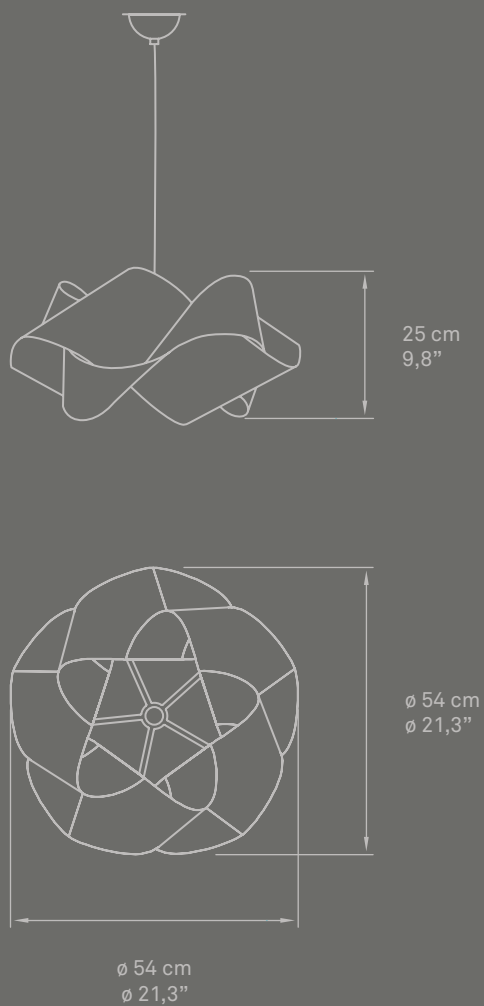





SWRL SP-21 Palau de Casavells. Art, Antiques, Design, Architecture. Girona, Spain.



SWRL SG-20 Palau de Casavells. Art, Antiques, Design, Architecture. Girona, Spain.

SWIRL

LARGE SUSPENSION

Ref. SWRL SG

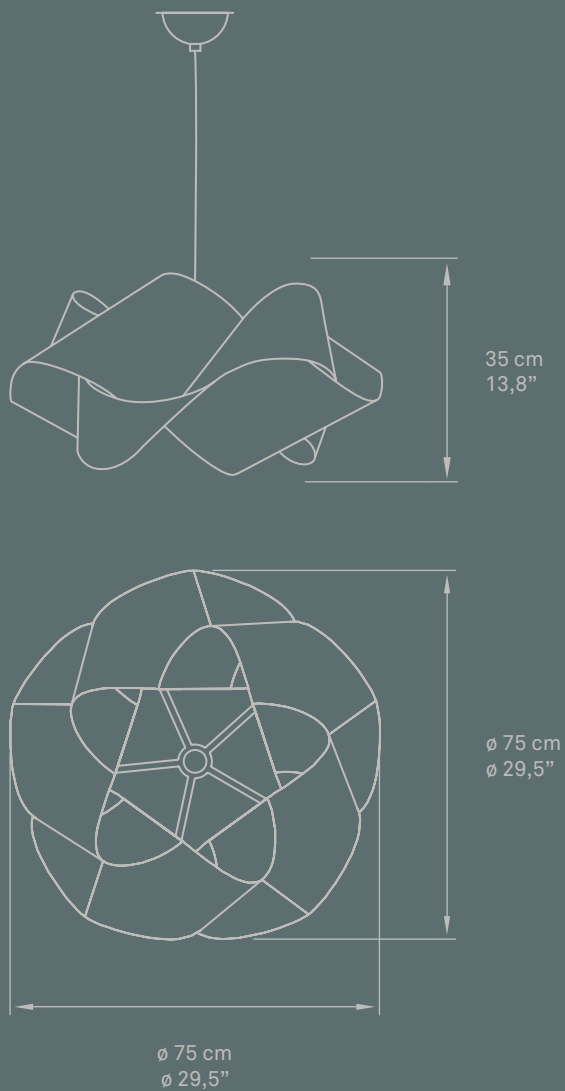



SWRL SG-29 & SWRL SP-29 La Monella Jewelers. Valencia, Spain.



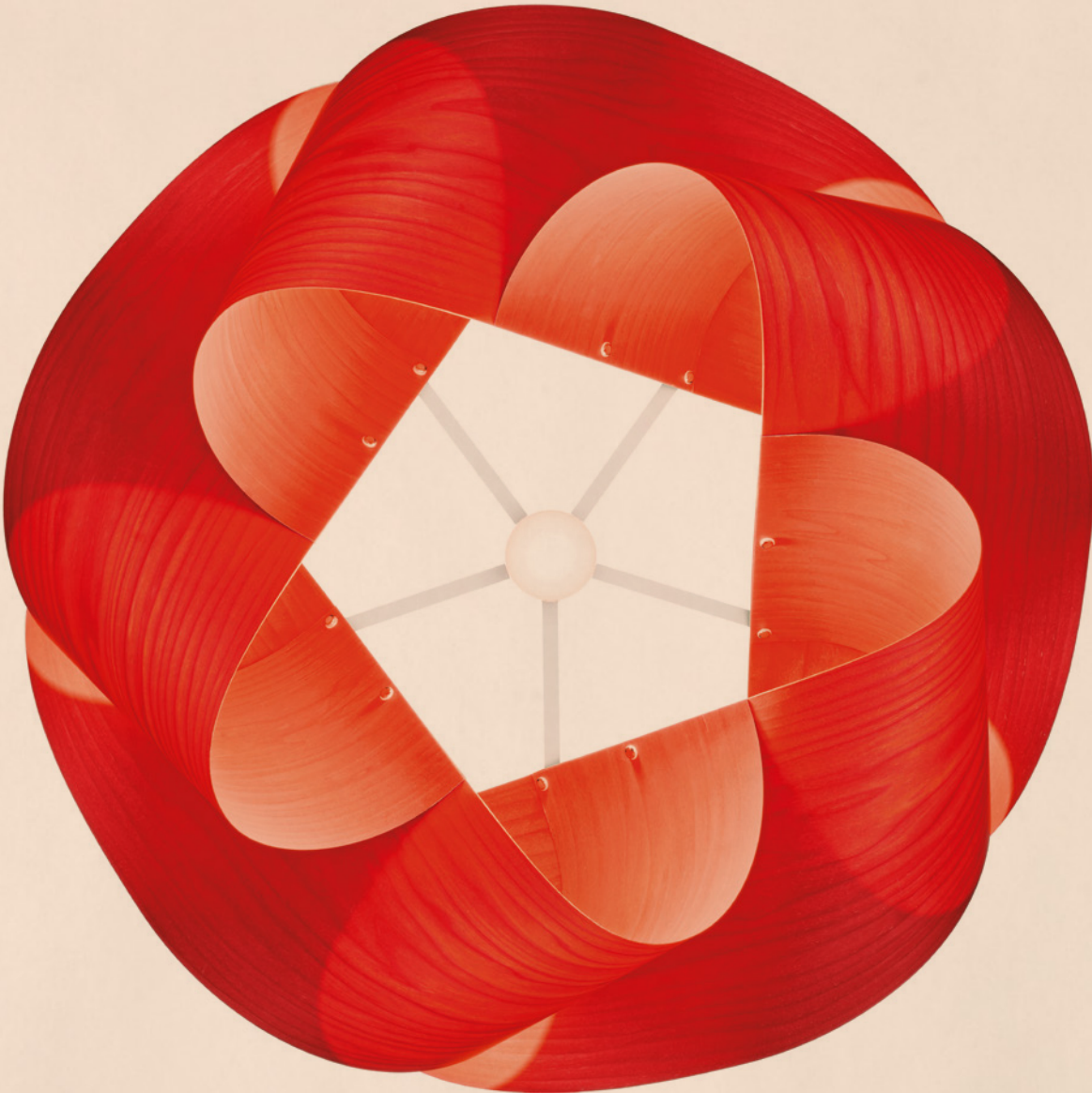

SWRL SG-26 (bottom view)



XXXV.

“This way, I can watch without being seen,” I
confessed.

“Like in tales from the orient,” he said.

—Así puedo mirar sin ser vista —le confesé.

—Como en los cuentos orientales —precisó.





TOTEM

**BURKHARD DÄMMER
& MARIVÍ CALVO**

FAMILY
SUSPENSION

TECHNICAL DATA
SEE PG. **562**



TOT4 S LED-20 & TOT3 S LED-20 Cubinyà. Barcelona, Spain

TOTEM 3 SUSPENSION

Ref. TOT3 S LED

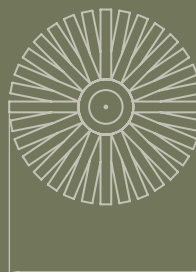



TOT3 S LED-20, TOT4 S LED-20, & TOT3 S LED-28 Palau de Casavells. Art, Antiques, Design, Architecture. Girona, Spain.





TOTEM 4 SUSPENSION

Ref. TOT4 S LED

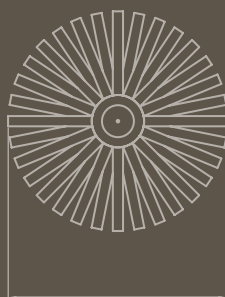

ø 86 cm
ø 33,8"



TOT4 S LED-21

Location:
Haarlem,
Netherlands

Architects:
Inge Bouman
Interior Architect

Photography:
Marloes Barnhoorn





TOT4 S LED-22



XXXVI.

“Dear Alice, do you really think one can walk in two directions at the same time?”

“I do it at least once a day. It’s fantastic.”

—¿De verdad cree que se puede caminar en dos direcciones al mismo tiempo, querida Alice?

—Yo lo hago una vez al día, es fantástico.



X-CLUB

BURKHARD DÄMMER

FAMILY

SUSPENSION / WALL

TECHNICAL DATA

SEE PG. **563**



X-CLUB SUSPENSION

Ref. X SM LED

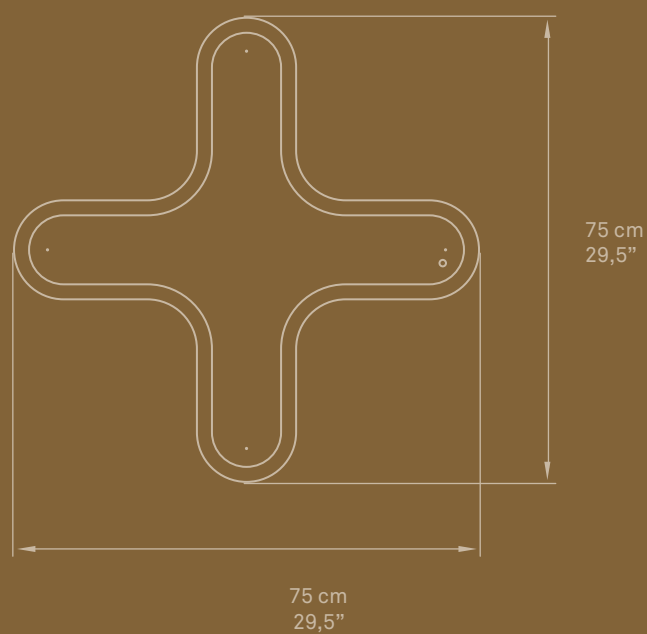
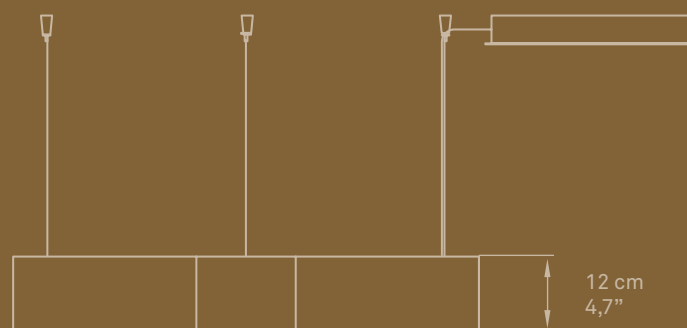



X SM LED & SG LED-24-26 Pharmacy, Switzerland.





X-CLUB

WALL & CEILING

Ref. X A LED

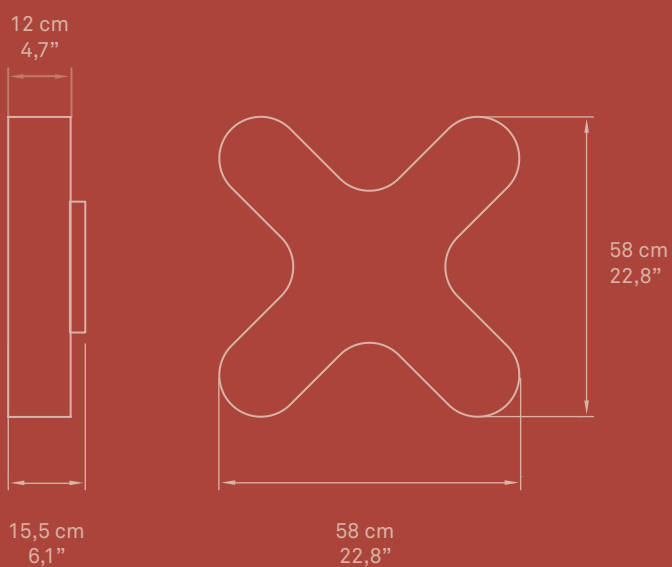





Photographic reproductions of our veneers can only be taken as a guideline to the actual colour of the veneers. Please use real colour swatches for tone matching as the wood's colour changes dramatically depending on the light source and the colour temperature of the bulbs. LZF will not accept any returns based on selections made using photographic reproductions.

Recommendations:

Avoid direct sunlight or strong indirect sunlight on the fixture. Exposure to the sun can change the colour of the wood over time. Please read all our instructions and recommendations on the use and care of our fixtures.

WOOD SHADE FINISHES

Timberlite[®]

The dramatic effect of light passing through the wood veneer is the essence and hallmark of LZF. This important feature would not be possible without the application of our patented process in treating the raw natural veneer: the Timberlite[®] system.

This system, the result of LZF's research & development work, allows us to work with an extremely flexible, yet very resistant veneer, which can take on many shapes without breaking. In addition to all our veneers being FSC certified, thanks to the treatment, the wood used to fabricate our lamps maintains its natural qualities, adopting different nuances and hues over time.



The mark of
responsible forestry

NATURAL TIMBER VENEER

SWITCHED ON



21 Cherry



22 Beech

COLOURED NATURAL TIMBER VENEER



20 Ivory white



28 Blue



24 Yellow



29 Grey



25 Orange



30 Turquoise



26 Red



31 Chocolate

Please only use these reproductions as a guide. Use LZF wood swatches to see the spectacular real effect of the illuminated veneers.



32 Pink

NATURAL TIMBER VENEER

SWITCHED OFF



21 Cherry



22 Beech

COLOURED NATURAL TIMBER VENEER



20 Ivory white



28 Blue



24 Yellow



29 Grey



25 Orange



30 Turquoise



26 Red



31 Chocolate

Please only use these reproductions as a guide. Use LZP wood swatches to see the spectacular real effect of the illuminated veneers.



32 Pink

LZF DESIGNERS
PRODUCT YEARS
LZF IMAGE LAB

PRODUCT YEARS

576

1995

Romanica / 233

1996

Gea / 155

1998

Nut / 279
Orbit / 287

2004

Mini Mikado / 261

2005

Carambola / 73
Cuad / 111
I-Club / 191
Saturnia / 347
X-Club / 415

2006

Guijarros / 173
Icon / 213

2007

Link / 231

2008

Pod & Poppy / 313
Totem / 403

2009

Agatha / 21
Air / 41
Screen / Paisley / 359

2010

Link Chain / 247

2011

Pleg / 305

2012

Raindrop / 325
Spiro / 367

2013

Candelabro / 429
Chou / 97
Domo / 129
Escape / 141

2014

Asterisco / 55
Link Modular / 247

2015

Cervantes / 85
Dandelion / 119
Elephant / 439
Fish / 447
Hi-Collar / 181
Koi / 453
New Wave / 269
Piknik / 297

2017

Banga / 63
Stitches / 377
Swirl / 391
Kim / 221

LZF DESIGNERS



Marivi Calvo



Burkhard Dämmer



Miguel Lorenz



Oskar Cerezo



Luis Eslava Estudio



Yonoh Creative Studio



Javier Herrero Studio



Remedios Simón



Rqr Studio



Cuatro Cuatros



Moratalla, Ortín & Planells



Burojet

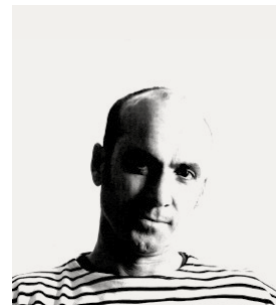

Isidro Ferrer

WEB

lzf-lamps.com

BLOGS

lzf-lamps.com/blog

DOWNLOAD CATALOGUE

lzf-lamps.com/download-catalogue

SOCIAL MEDIA

youtube.com/lzflamps

facebook.com/lzflamps

twitter.com/lzflamps

pinterest.com/lzflamps

instagram.com/lzflamps

plus.google.com/+lzflamps

PROJECT DIRECTOR

Mariví Calvo

WRITER

Grassa Toro

PHOTOGRAPHERS

Santiago Relanzón
Klunderbie

Jara Varela
Cualiti
Maria Mira

LZF GRAPHIC DESIGN

Ester Colomina
Miriam Castellano
Adrián M. Almonacid

PRINTED BY

Gráficas Vernetta, 2017

LEGAL ADVICE

©Luziferlamps, S.L. Valencia, Spain. 2017. All rights reserved.
LZF LAMPS reserves the exclusive right on all the trademarks, photographs and designs used in its offer, as well as on the commercial presentation of its products. Therefore, it is forbidden the manufacturing, offer, distribution and/or commercialization of the products containing them or its commercial presentation in any media or device.

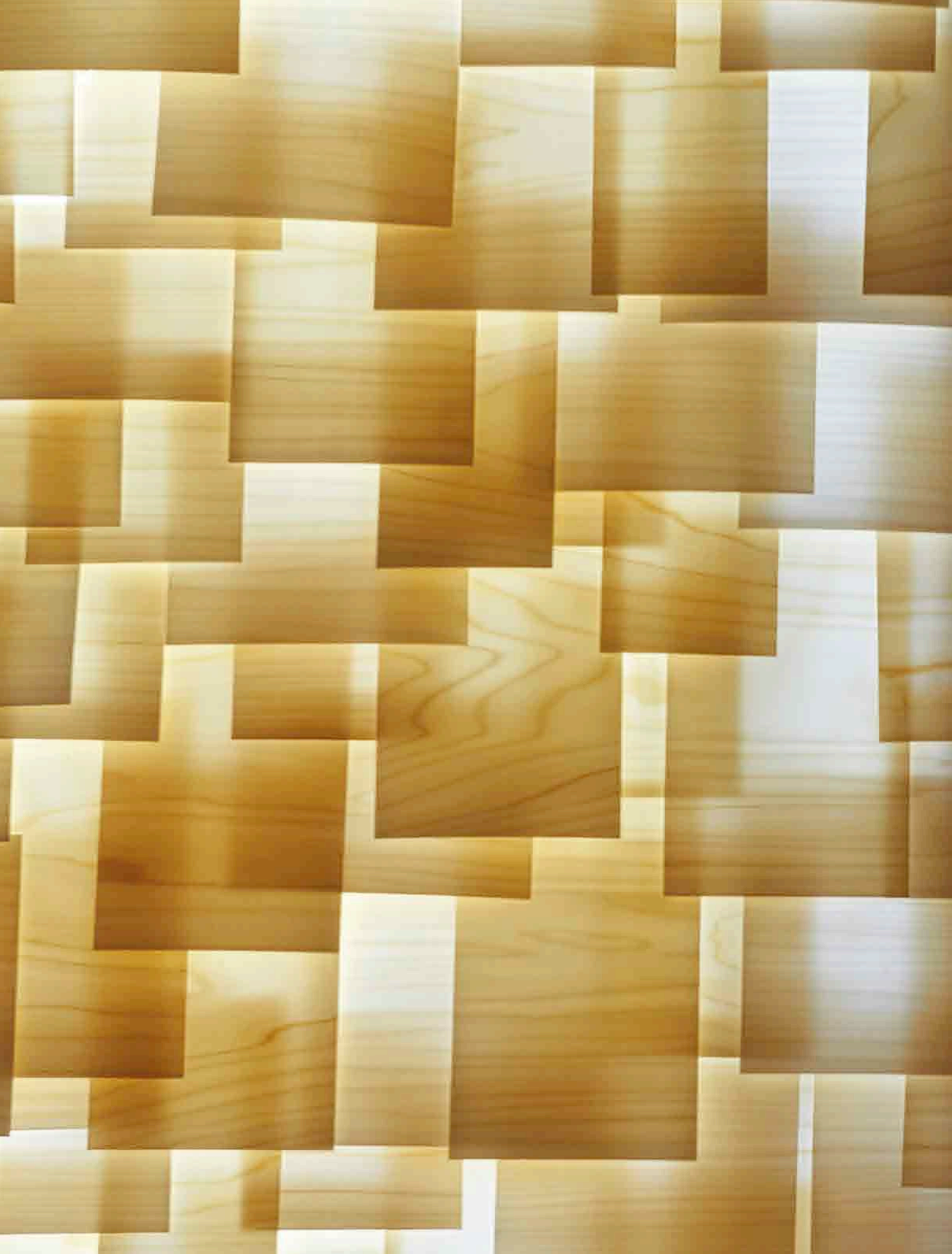



Wood touched by Light

Every LZF lamp is assembled by hand at LZF's manufacturing facility in Chiva, Spain; every piece is unique. The little differences become part of the charm; a rare commodity in a world of mass produced ubiquity.

www.lzf-lamps.com
contacts@lzf-lamps.com
(+34) 96 252 4780